

Vol. 22
2021 Spring

JEJU

Clean Island Where Human and Nature Coexist



The letter from Tamra



© "Choice of Jeju National Museum 30", 2009, P.40-41

Tamra (Three Kingdoms-Unified Silla)
Gonae-ri, Jeju
H 31.9cm, D 23.3cm

Gonaerisik togi

Gonaeri-style pottery



Gonaerisik togi, which has refined and sophisticated workmanship, is the representative pottery of Jeju in the late Tamra period of the Unified Silla period.

The earthen pots only differ from each other in size, but they maintain a similar shape overall, and the thickness is almost uniform at 0.8~1cm regardless of the size.

Unlike the pottery of the previous era excavated in other areas of Jeju, the pottery of Gonaeri reveals proficient skills to appropriately manipulate clay.

The form and structure are very stable, standardized, and commercialized.

In the light of these factors, it is presumed that the pottery was made in a professional and systematic production system.

Gonaeri-style pottery reminds us of Jeju Onggi today.

Most of Jeju Volcanic Island is barren volcanic soil.

On the contrary to other local pots that were gracefully crafted from easy-to-handle clay, Jeju Onggi, which was made of rough and barren volcanic soil, contains nature, water, soil, wind and stone in Jeju.

The strong life of Jeju people who have adapted to the given environment and sometimes overcome challenges.

There is the underlying strength in Jejuans through all ages.

From Tamra, in April 2021

CONTENTS

The letter from Tamra
Gonaerisik togi

PHOTO SKETCH 1·2



FEATURE 1 For the big step of Jeju

- 12 Bigger Jeju to open with cleanness and coexistence
Full-fledged implementation of Jeju-type New Deal
policy planning staff of Jeju Special Self-Governing Province
- 18 Meaning and Tasks of the Jeju 4·3 Special Act
Jeju 4·3, Is the flower about to bloom?
Huh Yeong-seon



FEATURE 2 Welcome spring to Jeju, the island of comfort, hope, and healing

- 26 Draw a normal daily life with the festival that came to my room
Go Si-yeon
- 32 Ritual scenes that make you fulfill the wishes of the new spring
in the new year Kang So-jeon
- 38 'Walking, running, picking up litter'
**Plogging to Improve your health and the beautiful Jeju
environment** Lee Hyeon-ju



SCENERY

- 42 Walk in Jeju
Beautiful Jeju Wild Flowers in Oreum
We are going to Tong-oreum Kim Seom
- 48 Walk in Jeju
"The Old Future" of Jeju Island, Batdam Kim Ji-taek



Subscribe to "Jeju"

Publishing office Jeju Special-Governing Province Publisher Governor Date of publication March 2021 (Spring issue, Vol. 22)
Editor-in-chief Public information office Editors Kang Eun-mi, Kwon Hee-jin, Kim Na-sol, Kim Yeong-heon, Oh Do-yeong, Jeong Ji-hyeong, Ju Min-wook, Jo Ki-seop
Address 6, Moonyeon-ro, Jeju-si, Jeju-do Tel. 064-710-2212

Planned, covered, designed, printed by MOG Creative Solutions / 064-757-0523 (23 Gwandeok-ro 15-gil, 3F, Jeju-si, #302 Korean Women Entrepreneurs Association)

Copyright © Jeju Special Self-Governing Province

All rights reserved. Reproduction and unauthorized copying of any content in this newsletter JEJU are prohibited.

All rights reserved. Reproduction and unauthorized copying of any content in this newsletter JEJU are prohibited.

Subscription is available at www.jeju.go.kr (news/online/story). (Consent to processing personal data needs to be given.)

If you scan the QR code with the smartphone camera app, it will go to the Jeju subscription page.



COMPANY

- 54 The time of the person
A Jeju woman who upholds the spirit of Jeju Island, **Yang Eui-suk** Kim Yeon-ju
- 60 Space and empathy
Meet Jeju Architecture by Kim Joong-up, a master of Korean modern architecture Kim Tae-il
- 66 Gastronomic habits
With eight legs giving you strong energy,
Mung-ge-juk(Octopus Porridge) Kang Jin-hee



LITTLE CHAT

- 70 The typewriter in the attic
If it rains or the wind blows Jwa Jung-muk
- 74 Samchon, please tell us more about Jeju
Jeju Geographical Names Reading in Jeju Language
Suwolbong Go Jae-hwan



CONNECTION

- 76 With Jeju
Jeju Agricultural and Rural Community 6th Industry Support Center Editorial Staff
- 82 Fine Jeju
Jeju, a leading electric vehicle city that practices Jeju's clarity
Editorial Staff
- 86 Wise Jeju Life
2021 more information, more benefits Editorial Staff
- 90 **Readers' forum** The postcards from readers
Jeju filled with my own color The landscape of Jeju winter
Coloring Jeju

COVER STORY



Faint spring vibes beyond the window

Illustration by Bae jung-yeol
215X275mm, mixed media,
2021

The time that the long winter was particularly hard has passed. I painted the spring landscape of Jeju in the hope that I could come back to the scenery of daily life.

PHOTO SKETCH 1



Spring in Gapado with green waves of barley

The spring breeze blowing through the paths of the green barley field awakens all the senses of the body that shrank throughout the winter, and the whole body is naturally filled with a fresh scent of spring.

Although you want to escape from busy and exhausted daily life, it is not easy to have a moment of relaxation in nature these days.



So here comes 〈Jeju〉 .
To share the warm spring of Jeju, we convey the spring of Gapado to you.



A king cherry tree native to Jeju Island

Currently, 235 king cherry trees are growing in Jeju.

It has become clear that king cherry trees are Korean indigenous plant species with pure authenticity and the old controversy over origin has already ended.



Unfortunately, most of the cherry trees around us are not native cherry trees originating from Jeju Island. Rather than cutting it down unconditionally, how about gradually replacing cherry trees all over the country with our own native cherry trees?

For the big step of Jeju

In the spring of 2021, the big step of Jeju has started. Eventually, the amendment bill on the Jeju 4·3 Special Act was passed in a plenary session at the National Assembly after a long desire and waiting. This move has been a trigger to heal the pain and wounds of Jeju 4 · 3, which had been forced to silently weep for a long time.

Just apology and forgiveness would not change the past, but Jeju's new step toward brighter future has become much lighter. In 2021, Jeju will heal and overcome the painful spring of 1947, and will strengthen the universal values of peace, justice and human rights as the cornerstone of Jeju society.

In addition, based on the “Jeju-type New Deal Comprehensive Plan” announced last year, Jeju is taking the big step toward the future of Jeju across the economy, culture, and industry. This spring it is even warmer in Jeju for Jeju's great step for hope and a giant leap forward and for reconciliation and forgiveness.





As part of the full-scale promotion of the “Jeju-type Green New Deal,” Jeju has built the first national floating offshore wind power generation system and started to realize a future smart hub city that connects it with electric vehicle power.

Photo- The appearance of Tamra Offshore Wind Power Complex in Hangyeong-myeon, Jeju-si

Bigger Jeju to open with cleanness and coexistence

Full-fledged implementation of Jeju-type New Deal

Written by
The policy planning staff of Jeju
Special Self-Governing Province

In October last year, Jeju announced the Jeju-type New Deal Comprehensive Plan to continue the process of strengthening "clean and safe" Jeju and to lead change and innovation in the post-COVID-19 transformation period. With the vision of "Clean Jeju, where people and nature coexist," the plan is made up of 24 priority tasks including 10 key projects designed to strengthen the three main pillars: ▲ Green New Deal ▲ Digital New Deal ▲ the reinforcement of social safety net. By 2025, it aims to create 44,000 jobs by providing a fiscal injection of KRW 6.1 trillion in total national and provincial government funds.

For the past 10 years, Jeju has been constantly seeking for coexistence with the clean environment and a real transition toward green mobility with the goal of a "carbon neutral island". Based on this experience, Jeju Province plans to actively implement Jeju-type New Deal as a "Green New Deal Frontier" to reform its industrial structure and secure new sustainable growth engines.

Since the announcement of the comprehensive plan, it has participated in external events and committees such as the 2nd Korean New Deal Strategy Meeting, the Green New Deal Expo, the 15th Jeju Forum, and the Joint Debate hosted by the Green Growth Committee and let Koreans and the world know Jeju's carbon neutral practices and experiences of the past period as a leading region for the Green New Deal. It has been showing accomplishments that a total of 44 projects, such as the production and demonstration of green hydrogen and the construction of artificial intelligence learning data using drones, have been selected as national public offering projects worth 101.9 billion won.

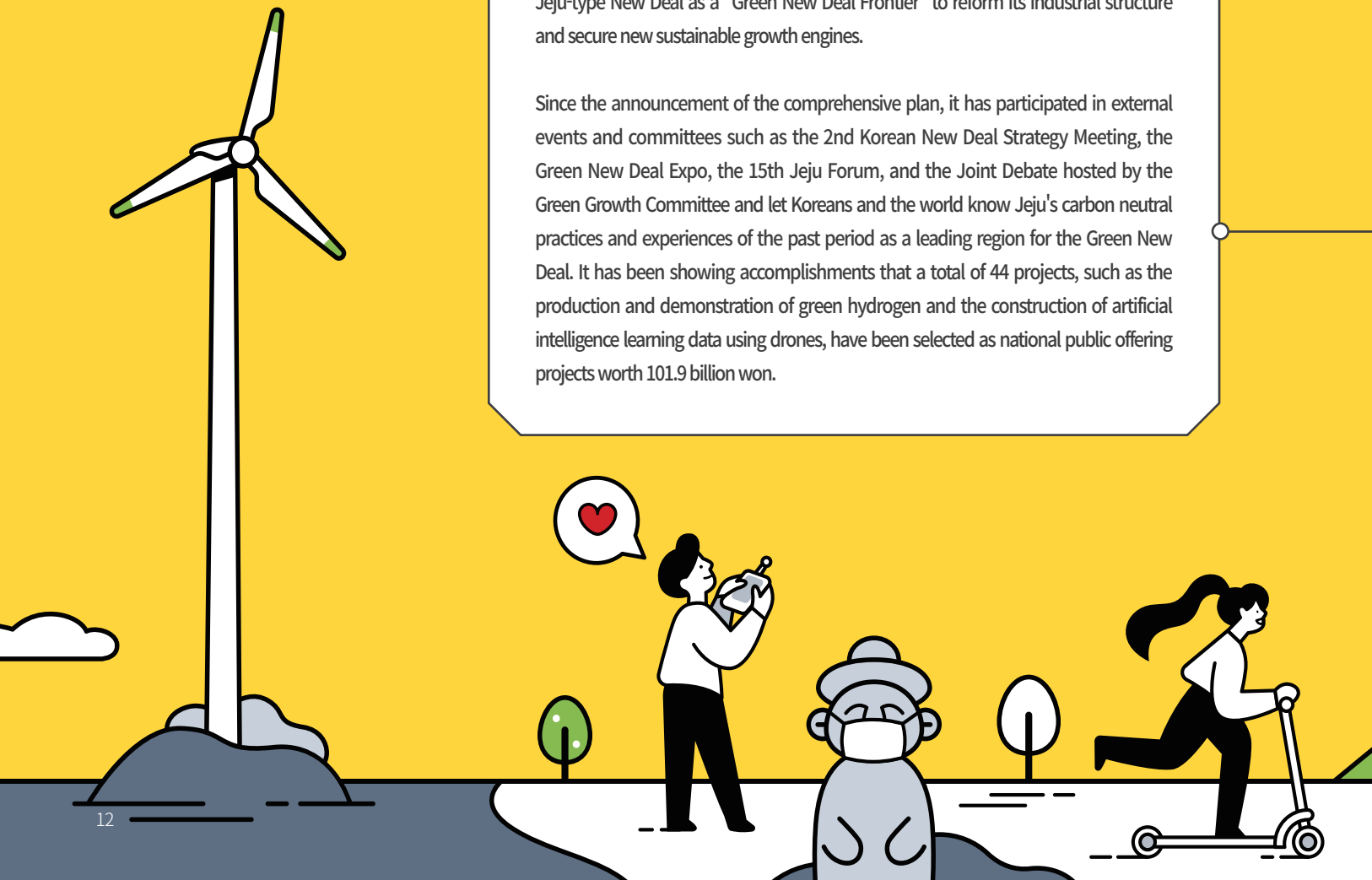

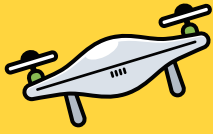

The direction for the implementation of Jeju-style New Deal

Investment of 6.1 trillion won

44,000 new jobs created

Clean Jeju, where people and nature coexist

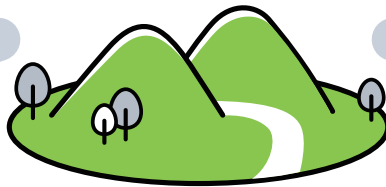

Green New Deal

Global Leadership
Carbon Free Island

- Carbon Free Island 2030
- The first national floating offshore wind power generation system

The Reinforcement of Social Safety Net

Citizen Security
Safety · Healing · Mutual
Growth Island

- Establishment of Science and Technology-based Quarantine System

Digital New Deal

The Solution to the Problem of
Regional Data Base
Digital Island

- Drone Special Liberalization Zone' Jeju
- Ultra-precision Real-time Fire Control Integrated Platform

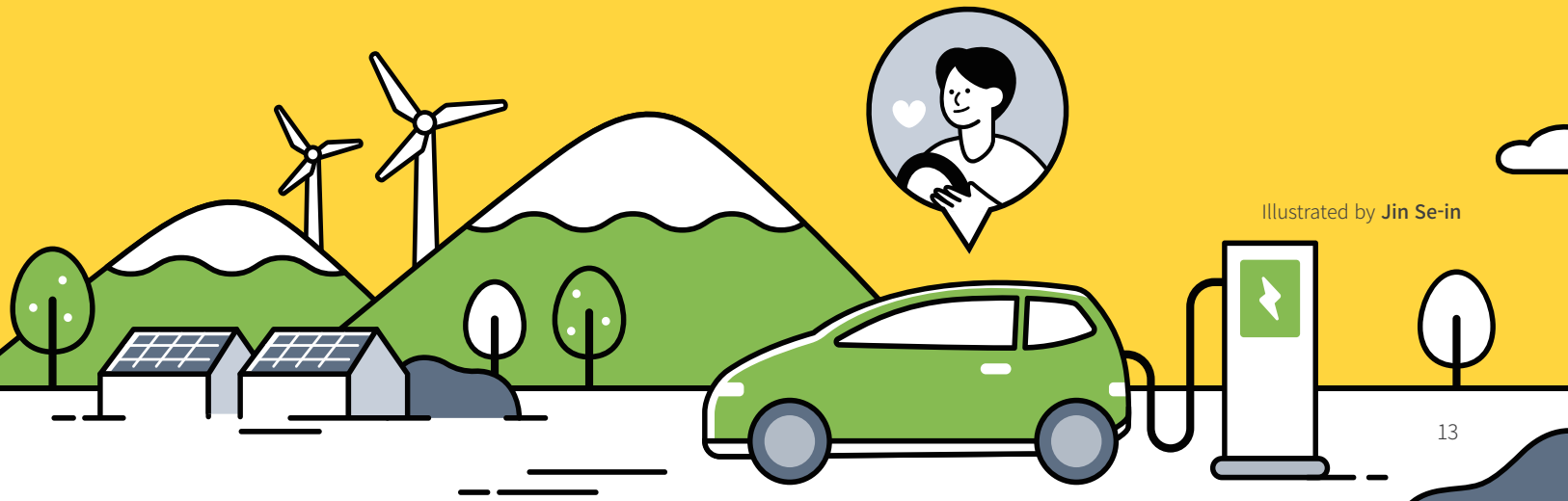

Illustrated by Jin Se-in

Full-fledged implementation of Jeju-type New Deal

In 2021, the first year of realizing the performance of the Jeju-type New Deal, Jeju Province plans to focus on conducting the projects from public contests for the Jeju-type New Deal and securing national budgets in response to the government's direction of the New Deal. The following are the main strategies for implementing the project in 2021.

❶ The Strategic implementation of the signature projects for Jeju-type New Deal

In 2021, in order to fully implement the regionally balanced New Deal, the government announced that it will select and manage about five signature projects by region and provide incentives for excellent New Deal projects by utilizing local share tax, etc. Accordingly, Jeju province plans to determine and manage signature projects that will lead to the transition and innovation of each sector, driven by the Jeju-type New Deal. Through discussions with the central government, related organizations, and provincial councils, it will coordinate and converge existing government funds and New Deal projects to discover the signature projects and actively seek to secure national funds.

❷ In 2021, the active involvement in government-led projects

Jeju Province is actively taking part in public contests after discovering project models for the public contests by government departments and establishing a cooperative system for each project. In particular, it manages to join in public contests in a timely manner through preparatory monitoring such as identifying the trends from government bodies and relevant central ministries. In addition, the Jeju-type New Deal Promotion Committee has formed an advisory council in charge of each sector to intensively support specialized fields such as the materialization of the project models and consulting.

❸ In 2021, the thorough preparation for securing national funds

Jeju Province is preparing its response according to the schedule for government budget allocations by forging a compromise with major government bodies and promptly proceeding with the preliminary procedures for each project. Through regular meetings, they are constantly monitoring the situation of government budget compromise. In order to enhance the feasibility of securing national funds, the performance of securing government budgets by department and the performance of Jeju-type New Deal are reflected in the performance evaluation of the department.

❹ The reinforcements of the connection and cooperation with public institutions

In order to secure the driving force of Jeju-type New Deal, Jeju Province intends to strengthen cooperation with the government and local public institutions. On March 15, Jeju signed a memorandum of understanding (MOU) with the Public Procurement Service for the "Procurement of Jeju Healing and Training Products Customized for Public Demand" in connection with the "public agency-led New Deal". In collaboration with municipal corporation and government funded institutes, Jeju-style New Deal convergence and representative projects are being discovered. In addition, the cooperation system will be strengthened in the future with the provincial government and national public institutions.

Additionally, in order to have the executive ability of the Jeju-type New Deal, the progress of the New Deal project will be regularly managed through the Jeju-type New Deal Promotion Committee. Meanwhile, it provides consulting on the New Deal Strategy and projects by operating advisory committees consisting of experts in and outside the province for each of the three major sectors. Furthermore, the "Jeju provincial government and council Jeju-type New Deal TF Team" will be regularly operated to continue cooperation such as sharing the progress and discussing the direction of implementation.

In 2021, Jeju-type New Deal Priority Strategy 4+α

Strategic Implementation of the Signature Projects
(Added incentive for outstanding New Deal projects)

Active involvement in government-led projects in 2021
(Preparatory monitoring for the public projects from government bodies and relevant central ministries)

Thorough Preparation for Securing national funds in 2022
(Securing government budgets by department and the management of the effect of performance creation)

Reinforcements of the connection and cooperation with public institutions
(The connection and cooperation to encourage public institutions to participate in the New Deal)



Operation of the Jeju-type New Deal Promotion Committee
Operation of advisory committees for the whole and each of the three major sectors
Operation of the Jeju provincial government and council Jeju-type New Deal TF Team

The Progress of the Three Main Sectors of the Jeju-type New Deal

Green New Deal

Global Leadership 「Carbon Free Island」

Jeju Province is going ahead with the Jeju-type New Deal based on the plan and implementation of the 「Carbon Free Island 2030」 Plan (CFI 2030 Plan). In order to foster the renewable energy industry, it aims to designate the 「Green New Deal Leading Area」, expand infrastructure to create a sustainable resource-circulating society, and strengthen the clean environment foundation in conjunction with low carbon mobility to realize a low carbon island that builds innovative growth engines without greenhouse gas emissions.

Carbon Free Island 2030

On March 3, the Ministry of Trade, Industry and Energy(MOTIE) announced a “region-led measures to activate decentralized energy” in Jeju, and Jeju officially proposed to the government to designate the nation's No. 1 decentralized energy special zone. The Ministry of Industry has announced that it will conduct conversion into a “distributed energy system” to create successful transition cases in Jeju and to spread this system across the country. If designated as a distributed energy special zone, it can be expected to solve the problem of power system instability such as easing restrictions on the output of renewable energy, and to create jobs by discovering new projects. In addition, Jeju has been selected for the first green hydrogen demonstration project in Korea and is carrying it out. By utilizing surplus power of renewable energy such as wind power and solar power, it is creating a Jeju-type hydrogen economy by demonstrating green hydrogen production and storage and expanding the supply of hydrogen cars centered on passenger vehicles like buses and large cars.

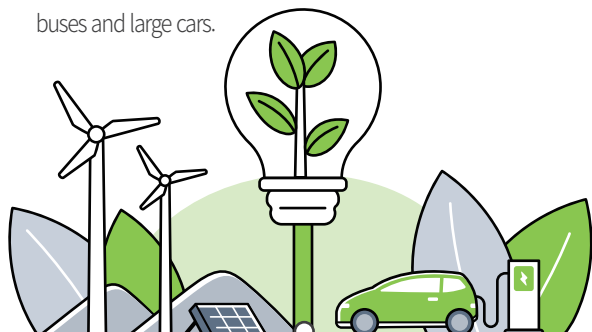

The first national floating offshore wind power generation system

Jeju Province has a plan to build the first national floating offshore wind power generation system on the sea. On March 15, it was finally selected for the floating offshore wind power system development project. The development of floating offshore wind power can reduce environmental damage such as site shortage, noise, and marine landscape, which are considered disadvantages of existing onshore and offshore wind power, and will lay the foundations for creating a breakthrough green energy ecosystem along with the green hydrogen demonstration complex project.

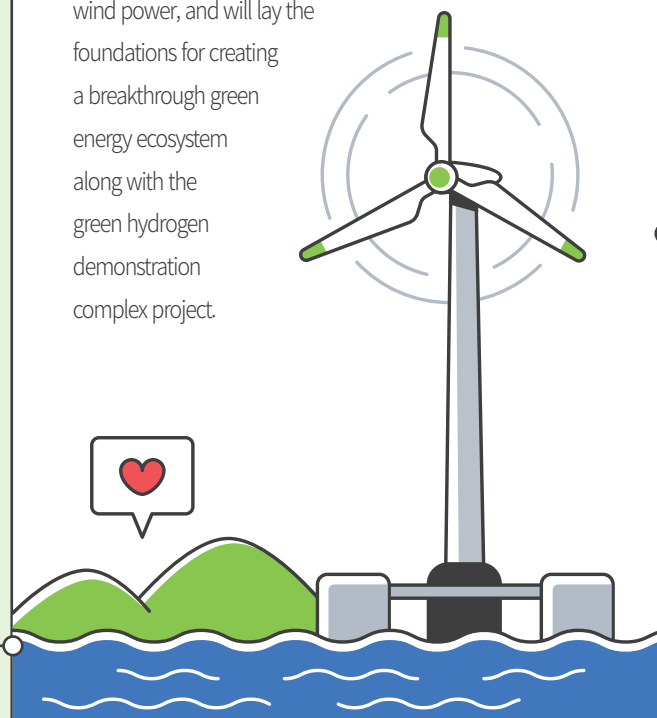

The Solution to the Problem of Regional Data Base 「Digital Island」

The Jeju-type Digital New Deal is to deal with the interests of provincial residents and to solve major pending issues in the region with smart and ICT technologies. By securing the autonomy of local data, it is pushing to foster new digital industries such as establishing smart urban infrastructure, digital transformation and innovation of cultural, tourism and primary industries, and building drone hubs.

'Drone Special Liberalization Zone' Jeju

On February 10, Jeju was selected as a drone special liberalization zone. Jeju is the only nationwide one to implement a project to build a drone demonstration city for two consecutive years since 2019. During the operation of the drone special liberalization zone, a full-fledged demonstration project is planned to secure a drone commercialization model. Monitoring the sky over the coast of Jeju will increase the efficiency of marine floating debris removal by utilizing solar drones and others. It is also planning to implement a drone-based safety service that complements CCTV blind spots using smart drones.

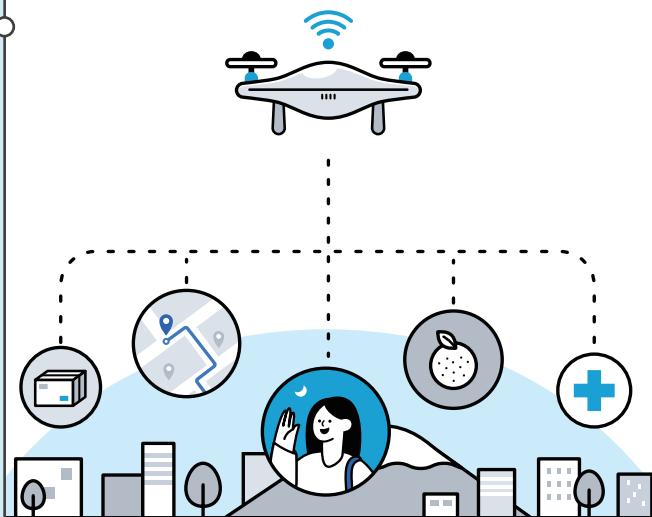

Ultra-precision Real-time Fire Control Integrated Platform

Reflecting the vision of the Jeju Digital New Deal, Jeju Province will establish the nation's first "data-based ultra-precision Real-time Fire Control Integrated Platform". With a system that guides optimized routes for emergency vehicles such as ambulances and fire trucks and integrates and manages on-site situations in real time, it is possible to secure the golden time on a scale of microseconds in emergency situations. It will lead the nation's smart first aid system by establishing a rapid response system in case of an emergency and an urgent disaster.



Citizen Security 「Safety · Healing · Mutual Growth Island」

Based on the thorough quarantine of Covid-19, Jeju Province will establish a “healing and curing” brand, and promote the protection and mutual growth of areas directly and indirectly vulnerable to Covid-19. For this, it is pushing steps to establish a smart quarantine system using ICT technology, to protect vulnerable population with Jeju-type welfare and digital healthcare and to seek renewal of culture and tourism using a healing and curing brand.

Establishment of Science and Technology-based Quarantine System

Jeju Province signed a memorandum of understanding with KAIST on February 9 to establish the nation's first science and technology-based quarantine system. Accordingly, the nation's first “Mobile negative pressure isolation room” developed by KAIST has been installed in the vaccination center. The mobile negative pressure isolation room is the same function as the negative pressure room in a hospital where patients with a confirmed infection caused by Covid-19 receive quarantine treatment, and it is planned to be used as a first aid room if they show abnormal symptoms after vaccination.

Furthermore, in connection with the New Deal led by public institutions, it plans to operate procurement services by discovering healing and travel products tailored to public demand through collaboration with Jeju Regional Public Procurement Service. Thus, it will make an attempt to revive the Jeju travel industry, which has been in a depression due to Covid-19, and establish a healing and curing brand. 



Mobile negative pressure
isolation room(MCM)

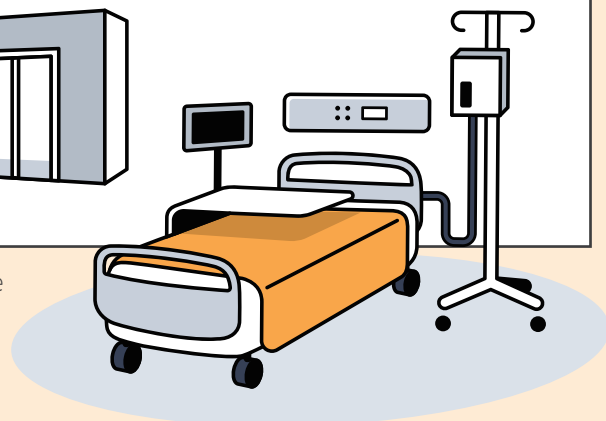

Meaning and Tasks of the Jeju 4·3 Special Act **Jeju 4·3, Is the flower about to bloom?**

Written and photo by **Huh Yeong-seon**, head of Jeju 4.3 Research Institute



Illustration by Heo Kyung-won

Is it because special days have successively come up this spring? Red camellia flowers on one side of the Tombstone Park for the Missing in Jeju 4.3 Peace Park have reached peak bloom. Through the leaves, there is a scene in which an elderly man of the bereaved family is bowing down. The “Special Act on the Investigation of the Truth of the Jeju 4·3 Incident and the Restoration of Honor of Victims” (Jeju 4·3 Special Act), which has been the wishes of Jeju Island for such a long time, passed through the National Assembly on February 26th. On March 16, in the Jeju District Court, 333 missing prisoners and two surviving prisoners were eventually acquitted by the state. It is the result of their surviving family with heartbreaking sorrow, their own blood and flesh, falling down and praying for them. As they were sentenced to innocence, the judge hoped that they have a peaceful sleep, conveyed his condolences and warm comfort. Numerous moments of cohesion has gathered and eventually rewritten history. And it means a new beginning.



The basic framework for a complete solution to Jeju 4·3

I cannot forget that the executives of the Jeju 4·3 bereaved families who went to the National Assembly erupted into cheers, shouting "Hurray!" at the moment when the amendment bill on the Jeju 4·3 Special Act was passed as the gavel is tapped by bipartisan agreement. These cheers were heard for the first time in 21 years since the enactment of the Jeju 4·3 Special Law in 2000 opened the path to restore the honor of the victims and their bereaved families.

In front of the National Assembly, a bereaved person said, "April 3 is innocent. I was watching this moment with the feeling of crying." Simultaneously, it brings back the 4·3 sons, daughters, and the people of Jeju who were desperate to hold a sign with their bodies in Jeju, at Gwanghwamun, in front of the National Assembly, and even in the snow and rain. Eventually, the problems of this island that had been so neglected, were solved and solved by the people of this island themselves. It is the Jeju 4·3 Special Law that strongly showed the process. It is of great significance that this amendment laid the foundation for a complete resolution of Jeju 4·3 following the 4·3 special law first enacted.

Individual compensation is the least responsibility the nation must demonstrate

What does the amendment bill on the Jeju 4·3 Special Act mean to us? What is this amendment for those who have gone through 4·3 and who have lived with a scar in their hearts for over 70 years? Let's look at some of the key implications of the entire amendment to the 4·3 Special Act.

First of all, the greatest significance is that the government has laid the groundwork for individual compensation for 15,000 people who have been determined to be victims of the public authority. While the Jeju 4·3 Special Act enacted in January 2000 focused on finding out the truth and "community compensation", the amendment was made with "individual compensation" and true restoration of honor as the main contents. It means the the government acknowledged that it was a violation of human rights by the public authority in the past and set new standards for actual compensation for damages. This clause establishes a definition of history for bereaved families who have persistently demanded that the government show sincerity in the wrongdoing of the public



The figure of a bereaved family offering a ritual at the Tombstone Park for the Missing in the 4-3 Peace Park

authority. This was also an essential process for the complete resolution of Jeju 4-3. Therefore, there were a lot of obstacles where it was struggling to reach a consensus with difficulty. However, these obstacles had to be overcome in order to become a good example of other past history, hoping to be a milestone in the just past history and compensation, taking the 4-3 as a model and the complete resolution of 4-3.

Of course, financial compensation could not relieve the pain of the bereaved that financial compensation follows, but it would be accepted as a meaning that the nation is responsible for national violence. I wonder if it may be the final gift that the victims leave to the living on earth.

Find the true name of Jeju 4-3 and raise the White Stone Monument

Another great significance of the amendment bill on the Jeju 4-3 Special Act is the establishment of the status at the national level through additional fact-finding investigations. For Jeju 4-3 it is true that there have been a lot of follow-up tasks since the "the Jeju 4-3 incident investigation report" was released in 2003. This additional investigation is meaningful because it should be the work of filling in the blanks in the initial report. In addition, this investigation should include a variety of issues such as the investigation for each village as an individual group and issues in the United States. While the government's first report was to investigate the overall truth of Jeju 4-3 and restore the honor of Jeju citizens, this additional investigation should be conducted to clarify the overall substance of Jeju 4-3 through a specific approach. This is because it is a process of further developing the truth of Jeju 4-3, which has still been buried, organizing and making efforts to engrave the correct name in the white stone monument through additional investigation. Currently, the number of victims determined by the Jeju 4-3 committee is 14,533, and the survivors are 8,452.

Above all, additional investigation needs a formal deliberation and resolution process. The committee has increased the number of four members recommended by the National Assembly, two from the ruling party and let an investigative subcommittee, including them, set up to deliberate on further fact-finding. After additional investigation, the results report should be published, and reported to the National Assembly. The Jeju 4-3 Peace Foundation will be in charge of the actual work of the investigation and the subcommittee and committee will be in charge of the additional investigation resolution.

The honor and the name of family that are finally taken back

For the prisoners who had lived with a red yoke like a prison of the heart for over 70 years, the path of honor recovery opened up. The prisoners of the military trial allowed the Jeju 4·3 Committee to request for retrial to the Ministry of Justice. It is also meaningful that the prisoners of the general trial allow for individual special retrial. The Jeju 4·3 Committee under the Prime Minister's Office recommended ex officio or collective review to the Ministry of Justice so that necessary measures could be taken. At the time of Jeju 4·3 in 1948 and 1949, at least 2,530 people were sentenced to military trials on the "List of prisoners," and more than 1,300 people were sentenced to general trials. Many of them were massacred shortly after the outbreak of the Korean War. It was surveyed that there were far more than 4,000 people who were all missing at the time of Jeju 4·3.

For Jeju 4·3, there are people who have some pain in my heart and are sick alone. The people who lost their parents are those who could not belong to Jeju 4·3 4 bereaved families. In the case of parents who did not even register their marriage, their children were enrolled in the relatives' family registers. Moreover, there are cases in which the people cannot become Jeju 4·3 4 bereaved one even though they were adopted and are performing a rituals for the victims. During Jeju 4·3 period, the surviving babies had to moved to some relative's register for survival. They had to live with an unwanted surname. In order to find their parents and ancestors, the twisted family relations register must be changed, but it was not time-consuming or administratively difficult for many people to sue in court. The Jeju 4·3 Special Act allowed the correction of the wrong family register only in areas where the family register was lost at the time of April 3, but these clauses have become an ineffective law. In this amendment, the prerequisite of "the loss of the family register" was deleted, but the phrase "due to the damages of the Jeju 4·3 incident" was inserted. It emphasized a more effective aspect.



After passing the amendment bill on the Jeju 4·3 Special Act on February 26, a commemorative photo is being taken in front of the National Assembly with a banner welcoming the revision of the special law.



On March 5, the "Amendment bill on the Jeju 4·3 Special Act for the Provincial Residents" was held. The location of the provincial residents' report meeting was in front of Gwandeokjeong, where the March 1st Independence Movement was fired in 1947, which became the trigger for Jeju April 3.



There is a special case of cognitive claims for people whose birth father or birth mother died and who were born illegitimate without being listed on the family register. Within two years after the enforcement date of the law, the corresponding person can file a cognitive claim against the prosecutor.

In addition to these causes, this amendment provides a more efficient Jeju 4-3 trauma healing project to heal the physical and mental damages caused by the Jeju 4-3 incident, as well as a special case for claiming disappearance to clear legal relations related to victims who have been determined to be missing. It is also meaningful in that the government has provided relief for victims and bereaved families and provided support measures.

The amendment is only the beginning, and it is important to prepare a follow-up plan and implement it promptly

However, it should also be considered that obstacles are put in the way for these amendments to become a reality. Of course, you must not expect too much at your initial attempt. The amendment bill on the Jeju 4-3 Special Act will be implemented after three months through preparation of enforcement ordinances, etc. The government started the service last month in response to the opinion of the 4-3 Special Act, which promptly prepared a support plan. Here, first of all, the tasks to be solved, such as the compensation issue, which is drawing the attention of the bereaved families, are not easy. Above all, the Ministry of Public Administration and Security, the current department in charge, will discuss the results of the service in August through supplementary legislation to prepare measures to support their compensation as soon as possible. This is because, standards such as appropriate compensation amount, payment procedure, and scope of payment will be arranged after intense discussion. When supplementary legislation is implemented, compensation will be paid possible from next year.

According to the Jeju 4-3 Special Act , there is an opinion that the heirs may be different from those of the right of inheritance under the Civil Law, because if there is no direct lineage, even if a rite is performed or they take care of the tomb as collateral blood relatives within the fourth cousin, they can become a bereaved family. That is why their various cases should be discussed and it should be the most reasonable part since it could trigger family conflicts due to differences in compensation.

When the Act is implemented, it will proceed with a package of procedures for retrial for prisoners of military trial, and legal readjustment of missing victims.

When the results of the service are released, the government should take steps to revise the Jeju 4-3 Special Act



based on this. The process must also be clearly watched to see if these things are going properly. That is why you can't be vigilant.

Another challenge is how far public authority will be in the process of conducting the additional investigation among the "additional matters for investigation" added to the April 3 Central Committee's deliberation and resolution. We need to cohesively with the mind that this is our last chance.

In addition, while there are bereaved families who are inviting expectations with the correction of a family relation register, there are many various cases such as bereaved families who do not have any specific verification method. It is necessary to be careful to find their right roots so that bitter resentment will not come up. Their tortuous family history was not their choice.

Furthermore, the dead are objects of mourning. Unfortunately, there are still excluded people who you must embrace through reconciliation and coexistence. Indeed, do you pay attention to them?. The 4-3 flowers are about to bloom, but we must not forget that there are still people who shed tears on one side. This is also the 4-3 we have to go through.

The government has bowed its head to those who were unjustly sacrificed by Jeju 4-3, and after 70 years, it laid the foundation for fulfilling its responsibilities. In the future, if the National Assembly approves and promulgates all of the amendments to the 4-3 Special Act, the complete resolution of Jeju April 3 and the settlement of just past history will go further.

Therefore, efforts to clarify the truth and restore their honor on Jeju 4-3 must keep going. Because it is a duty that the living must do for those who have not returned.

In honor of passing the amendment bill on the Jeju 4-3 Special Act

After the amendment bill on the Jeju 4-3 Special Act was passed, I wrote a poem in honor of it. 🌸

On the days when the person who I saw in the morning disappeared,
I couldn't see a hair of a person and a leaf of grass
To people who got innocent guilty without sin
under the law, not the law.
To people who closed their eyes and mouth
when insults and shame meant nothing under the law, not the law.
Now I ask once under the law
Have flowers bloomed there?
Flowers are about to bloom here.

(From 「Under the law」)



Welcome spring to Jeju, the island of comfort, hope, and healing

Jejudians do not take it for granted that spring always comes every year, so they have never sluggishly greeted spring in their homes. At the end of Singugan, when it's thought that the island's 18,000 gods return to heaven, they summoned the gods with an exciting gut to welcome the coming spring.

They burn everything that is harmful themselves like wildfire, and wish each other's well-being and happiness by sharing food prepared with great care. Jeju people welcome spring by sharing and wishing for small things, comforting each other, becoming hope, and empathize with others' pain.

Here comes spring again. Whenever we see spring flowers in full bloom in the field, that fact that it was a flower that blooms every year has never made us remain impassive. Regrettably, this spring, we welcome only with our heart and express our gratitude to this spring only with our eyes. When was Jeju's springtime, which continued like a festival, so calm like these days? But fortunately, Jeju's spring is still beautiful and dazzling. Let's welcome Jeju's hopeful new spring together.



Most of the spring flower festivals have been canceled due to COVID-19.

Alone, friends, loved ones, family, etc., the least number of people enjoyed the spring flowers.

Photo_ Jeonong-ro Cherry Blossom Road, Jeju-si

Draw a normal daily life with the festival that came to my room

Written and photo by Go Si-yeon, reporter of the Ministry of Culture of Jeju Ilbo

The novel coronavirus infection (COVID-19), which came suddenly last year, has changed many things in our daily lives. Ordinary daily life has become something that is no longer normal, and the distance between a person and a person has become increasingly distant.

Events that could attract a lot of people have been canceled one after another, and festivals that were held on-site moved online. The Jeju spring festivals, which took a break last year amid the changed environment, have been converted into non-face-to-face festivals using an online broadcast platform instead of "cancellation" this year to meet with provincial residents. Although

it is not possible to enjoy the boisterous atmosphere at the site, people who enjoy festivals in their own spaces communicate by comments beyond time and space, share

In the COVID-19 era, festivals comfort the hearts of people who are tired of the long "zipkok", stay-at-home, life, and serves as a channel of communication that connects with people in the era where it is difficult to talk face to face.

A spring breeze is blowing softly in Jeju as if it comforted us through tough times. Let's take a look at the representative Jeju spring festivals that heal the hearts of those suffering from the Covid blue and deliver hope to the local community.



**Wake up Jeju's
spring with "gut"
praying for daily
recovery**



With the "2021 New Year's Tamnaguk Ipchungut" held in Gwandeok-jeong, Jeju-si, the day before the opening day, 'Nangshekosa', which recreates the life of a kosa after making nangche (木牛) and tying it with a string, was broadcast live online. Photo by Go Bong-soo, reporter of <Jeju Ilbo>

The first festival that awakens Jeju's spring is the "Tamnaguk Ipchungut". Tamnaguk Ipchungut, Tamra Guk Ipchungut, hosted by Jeju City and organized by the Jeju People's Artist Federation, is a traditional cultural festival in Jeju where the soul and spirit of ancient Tamra breathe alive. Japanese colonial era Folklorist Dr. Moon Moo-byung, who was cut off by the policy of exterminating ethnic culture, has been in flux since 1999. In 1999, Jeju culture expert Moon Moo-Byeong restored Tamnaguk Ipchungut, which was cut off by the policy of eradicating national culture during the Japanese colonial period and it has continued. The festival, which was completely cut off from tradition, has been passed on by descendants today with the principle restoration theory of Jeju gut and the framework of modern urban festivals. Today's descendants have been handed down a festival that has completely ceased to be, with the principle of Jeju Gut's restoration theory and a modern urban festival. However, it could not continue last year due to the impact of COVID-19.

Under the theme of "The Day We Become Spring," "2021 New Year's Tamnaguk Ipchungut" was held at the old Jeju provincial government office of Jeju Mokgwana for two days on February 2 and 3. This year, the festival was held in a non-face-to-face online live broadcast with a minimum number of people attending. On the first day, the 2nd, starting with "Chungyeongmungut," which prevents evil and wishes for abundance, "Saekyung-gut," "Chilsung-gut," "Sarilsaeseong," "Ipchunhuiho," and "Nangshekosa" were held around Gwandeokjeong area to pray for prosperity and well-being. On the 3rd of the new year, the "Jeju Gut Preservation Society" held the main event, "Ipchungut". At Ipchun-gut that day, "Chogamje",

"Heo Meng-i Dapdori", "Manura-baesong", "Dojin", and "Makpudashi", and so on were held.

Traditionally, when they got sick, Jeju people used to do gut because they thought it was because of the anger of the gods. At this time, they made "Heo Meng-i (Jeju dialect for a scarecrow)" out of straw, paper, or cloth, and beat it with bamboo, doing "Dapdori (Jeju dialect for scolding loudly)". They blamed it for bad things, not their inability and faults. This is called "Heo Meng-i Dapdori." In addition, there was a folk belief that smallpox was called "Manura" or "Manura of Seoshin-guk" and enshrined it as a "big guest". It was thought that it was necessary to beg and treat well to the "Manura" to avoid getting sick and to get rid of disease. This is the "Manura" to avoid getting sick and to get rid of disease. This is called "Manura-baesong."

"Heo Meng-i Dapdori" and "Manura-baesong" are both one of the rituals of Jeju's unique folk beliefs and humor. This was the first time this year, praying for the end of COVID-19 in the hope of recovering from all difficulties and an epidemic.

This year, Tamnaguk Ipchungut gave a unique experience to those who enjoyed the culture of the Untact Era by unfolding new attempts in line with the changes of the times while preserving the tradition.

The citizens could not enjoy the event in the spot, but they shared their opinions by communicating in real time and communicated through Jeju People's Artist Federation

's YouTube account. In addition, "Gut", which was broadcast live in real time, was added with explanations and subtitles from the festival organizers, so it helped strangers to understand Jeju traditional culture



Carry a torch for hope in hopes of the end of the COVID-19 pandemic

At the Jeju Fire Festival held in March, the phrase “Wildfire, COVID-19 OUT,” expressing the wish for an end to COVID-19, is burning.

and added fun.
Pre-events such as Ipchun-noodle, writing wishes, and writing names on Gutpan were also conducted through online participation in which each person made them at home and posted them on social media, provoking enthusiastic response.
The citizens actively enjoyed the event by posting their photos related to Ipchun-gut on social media.
Jeju City held the 23rd Annual Jeju Fire Festival from March 8th to 14th at Saebyeol Oreum, Aewol-eup, under the theme of "Wildfire, live with hope!"
The Jeju Fire Festival, which has been established as a representative festival of Jeju with numerous tourists and provincial residents visiting every year, suffered the pain of canceling the event due to COVID-19 last year.
As the event was canceled last year, this year's fire Festival was scheduled to be held as a participatory event for local residents by organizing various side events such as Oreum hiking, busking and artist performances during the event period.
However, as the spread of COVID-19 continued across the country, Jeju

City canceled all scheduled face-to-face events, and switched to non-face-to-face events such as drive-in and drive-through through online and the advance reservation system.
In preparation for this year's event, Jeju City put the phrase 'Wildfire, COVID-19 OUT' in silver grass on the uphill with a wish that the pandemic would end as soon as possible.
On March 13th, at 7 pm, a firework feast unfolded as the fire was set on 300,000 square meters of the oreum, which is the same size of 42 soccer fields. The participants in the event online and the pre-booked guests in 400 vehicles exclaimed in excitement for the huge fire feast, and wished for a new year with the end of COVID-19. On the oreum ridge, 43 hay bales (moon houses) were installed to burn the vast oreum. After the fireworks followed by setting the oreum fire, augmented reality (AR) technology, enabling a livelier experience for viewers was introduced with fire burning.
The fire Festival was broadcast live on YouTube (www.youtube.com/wowjeju), and cultural, exhibition, and experience events were held online non-face-to-face during the festival.
Thousands of people who watched the fire Festival at the same time



With mascot "Buriburi"

Origin of the Jeju Fire Festival



1. Saebyeoloreum in preparation before setting the fire
2. The 2021 Jeju Fire Festival is a "drive-in" festival in a thorough quarantine system. Through pre-booking, participants of the festival took part in the Jeju Fire Festival in the car while maintaining a certain interval.



You can view the video of the "23rd Jeju Wild Fire Festival" through the QR code.

The Jeju fire Festival originates from the fire, the origin of Jeju's volcanic island. The fire of Jeju, a volcanic island, gave birth to Mount Halla and raised more than 300 oreums, and has been the driving force for the history of the Tamra millennium and the lives of Jeju ancestors. 'Bangae fire (wildfire)' is a product of the history of Jeju's ancestors who have been breathing with nature to open a brighter future while overcoming harsh environments. By the time new spring came, fire was set in the pastures of cattle and horses to remove harmful pests such as mites to obtain fresh quality grass that is good for feeding livestock, and the burnt ashes made agricultural land more fertile for farming, leading a life in harmony with nature.

The Jeju Fire Festival is a cultural tourism festival that reproduces Jeju's old pastoral culture, "Bang-ae," in a modern sense. The Jeju Fire Festival began in 1997. At that time, Shin Cheol-ju, the head of Bukjeju-gun, set fire on Saebyeol-oreum in Bongseong-ri, Aewol-eup, after passing through Eoum in Aewol-eup and Deokcheon in Gujwa-eup to pray for longevity, prosperity and well-being and to eliminate bad luck and negative energy. Every March, a fire is placed on Saebyeol-oreum by bringing embers from Samseonghyeol, a sacred place in Tamra nation.

Since 1997, the festival had been held every year on January 15 of the lunar calendar, during the fifteenth day of the first full moon of the lunar calendar. However, it was changed to Gyeongchip after 2013 due to predictable weather patterns on the day of the festival.

By the time new spring has come, the wildfires like red bloom turn the middle of Jeju red. The festival has become a flower of Jeju tourism.

The Jeju Fire Festival was first designated as a promising festival by the Ministry of Culture, Sports and Tourism in 2006 and promoted to an excellent festival in 2015. Also, it was designated as the "Culture and Tourism Festival" designated by the Ministry of Culture, Sports and Tourism for two years from 2020 to 2021, following the 2019 Best Festival by the Ministry of Culture, Sports and Tourism.

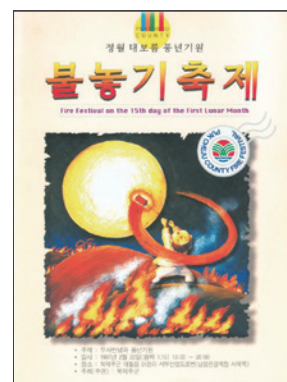

1997년 제1회 들불축제 포스터



Enjoy Jeju's spring
flower festivals in a
car this year



through online broadcasts left comments such as "I hope that COVID-19 ends soon" and "I want to directly see great scenes at the site with my family and loved ones next year." Truly, they hope to get back to normal life.

One of the representative spring flower festivals in Jeju, the Jeju Canola Flower Festival takes place this year in the form of a "drive-in" where you can see flowers in your car. Seogwipo City holds the 38th Jeju Canola Flower Festival in the area of Noksan-ro, Gashi-ri, Pyoseon-myeon, for 3 days from April 6 to 8.

Seogwipo City took action such as canceling the Canola Flower Festival and canola flowers being trampled to prevent tourist gatherings as the stage of COVID-19 crisis was raised to a serious level last year.

However, this year, a festival is held to comfort the local residents who were tired of the prolonged period of COVID-19 with thorough quarantine measures to prevent infectious diseases.

In addition, vehicles are banned from parking and stopping at major sowing sections of canola flowers, which are about 4km from the entrance of Noksan-ro Jeju Samnong to the parking lot of Jeongseok Air Center. Safety personnel are assigned to induce a "drive-in flower seeing" where visitors can enjoy canola blossoms while in a vehicle.

Quarantine stations are set up in the canola flower square to manage



This year's Noksan-ro canola flower festival in Kashiri was held as a non-face-to-face festival through online live broadcasting. Visitors to the event were allowed to enjoy canola flowers while boarding the vehicle.

quarantine such as heat check and hand sanitization. Meanwhile, safety personnel will be deployed to prevent large crowds from concentrating in one place even within the square.

Furthermore, Seogwipo City prepares to broadcast live online so that you can enjoy the beautifully bloomed canola blossoms online without visiting the site, and plans to produce related videos and release them through the Internet. 🌐

3. Last year, Jeju Island took an extraordinary measure to overturn the entire plantation site of canola flowers in Noksan-ro, where there is a concern that Sangchun visitors would flock as part of the Corona 19 quarantine measures.
4. During the Canola Flower Festival, real-time online live broadcasts are provided so that everyone can enjoy the festival together in the home. '38th Jeju Canola Blossom Festival' live broadcast video QR code on the first day.
5. The Jeju Yoshino Cherry Blossom Festival, which was held every year, was completely canceled this year following last year. 2019 Jeju Yoshino Cherry Blossom Festival pamphlet





Ritual scenes that make you fulfill the wishes of the new spring in the new year

Written by **Kang So-jeon**, doctor of literature and a lecturer of Korean Language & Literature, Jeju National University

New Year's Day's Bonhyangdang-gut and Singwaseje (新過歲祭)

At dawn, when the darkness is still dark, the wives of each family in the village leave the house with their own bamboo guduk (basket) on their backs. The cold winter weather makes their bodies shrunk,

but they refrain from saying a word and head to the Bonhyangdang Shrine. The residents, one by one, offer offerings to the altar of Bonhyangdang. The offerings such as boiled rice, rice cakes, boiled eggs, grilled fish, fruits, vegetables, and soju are simple and humble. They put the paper with the names of the family members into a rice bag and put it neatly in front of the altar in the order in which they came to the shrine. We exchange eye greetings with each other and wait for the simbang, who is in charge of the shrine, to start the gut. After telling all the names of the residents to the god of Bonhyangdang, the simbang finally begins the gut to herald and

greet the coming of New year in the village.

This danggut, which is held every New Year, is Singwaseje. In the New Year, villagers gather to greet the god of Bonhyangdang, who protects the village. As the simbang invites the god, he or she sings the Bonpuli(oral epic poetry of gods in Jeju) and then delivers the wishes of the villagers who hope their home and the village are peaceful and safe this year. At the end of the gut, the simbang foretells the fortune of the new year using the rice brought by each of the people who visited the dang. The villagers who have checked their fortune take a small bite of the offering and return home. This is the village's first lunar month scene that has been handed down from generation to generation. Now we're also in the era, today, when Lunar tourism could soon be a possibility, but the power of traditional culture, which lives under the care of the gods, has also remained highly influential.

There are plenty of shrines in Jeju. In the literature at the beginning of the 16th year, it was said that there were approximately 300 shamanic shrines, and surprisingly they remain similar today, showing the persistence of the local shamanic religion "dang". After

The Dongjaseoks with a wishing camellia flower for the well-being of this spring. They symbolize 18 sons and 28 daughters that were born to the goddess, Baekjuto and Sorosochonguk and the god of the Songdang Bonhyangdang. ©The Jeju Culture and Arts Foundation, the Jeju Tourism Organization



the village was formed, dang is a sacred place with villagers' religious beliefs. The shape of dang is very diverse, usually with a sacred tree (Shinmok) and an altar made up of stone walls. A hole called "Gwe" is made to put the offering for the god. They hang Jijeon (紙錢)(paper money), thread, white paper, and a piece of cloth around Simmok and pray. Jeju's dangs can be divided into several types according to their character. Among them, "Bonhyangdang" is the most important place to take care of the safety and the prosperity of the village, and the birth and death of the villagers. The myth of dang is still alive in Jeju. When Danggut is held every year, festivals of myths take place throughout villages on Jeju Island.



Singwaseje held at Bonhyangdang in Wahl-ri in Jocheon-eup, Jeju-si
©The Jeju Tourism Organization

**Another scene of
the New Year's
village rituals,
Confucian style
Poje (醮祭)**

The village leaders gather at the Ri-office (community center) to hold a village meeting. They discuss how to proceed with the village ritual of the New Year this year. The name

of this village ritual is usually called "Poje". It is organized by the village males and carried out in the Confucian manner. They set the date of Poje, select participants for performing the ritual, and decide how to prepare the expenses and various offerings. As the date of Poje comes up, the whole village becomes solemn after Pojedan (place for village rituals) is arranged and all preparations are completed.

If a village holds the ritual for the safety of the village, other official events in the village can only be started after this ritual. A banner announcing Poje hangs out, and the male residents in charge of the ritual get serious.

The men in charge of Poje gather at the Poje Hall to stay together. This is because the body and mind must be purged and cleansed. The ritual prayers for Poje is carefully written down. The person in charge of the event repeatedly learns the order of progress of the ritual. Ritual robes such as Cheonggeum (靑衿) and Yugeon (儒巾) are also prepared. Just in case, a rehearsal takes place the day before the date of Poje. When some men who are not familiar with the process of poje sometimes stumble, everyone bursts into laughter. Finally, when it is time for Poje, the hours between 11 p.m. and 1 a.m., they head to Fojedan and hold a village ritual. A whole pig is offered as a sacrifice, and various grains and offerings are

carefully prepared. They bow down to the sound of breaking the darkness, saying, "Gukgungbae(鞠躬拜)". After giving written prayers for the well-being of the village, A dink is served to the god of fortune and the god of earth. After the ritual is over, they drink together. Now that the Poje has been safely completed, the village will continue to flourish even in the New Year without worries after the darkness is cleared.

Village rituals in Jeju can be divided into Dang-gut, a shamanic ritual, and Poje, a Confucian ritual. In the past, Dang-gut, a shamanic ritual prevailed. It is presumed that It is estimated that Poje, a Confucian ritual began in the mid-18th century, during the late Joseon Dynasty, as Confucian rituals gradually spread to local communities on Jeju Island. As the Confucian Poje became male-dominated , Dang-gut, a shamanic ritual became dominated by women. There was a phenomenon in which the village system was divided according to the manner of the rituals and the division of men and women. In other words, a significant change were brought about in the tradition of village ritual. The name Poje is the most common, but depending on the village, it is also called Nongpoje (農圃祭), Risaje (里社祭), Kukje (局祭) and so on.



Yeongcheon Poje in Seogwipo-si © Jeju Special Self-Governing

Yeongdeung-gut and Jamsu-gut, the abundance of sea in the spring

For haenyeo, the sea is another field. The sea can only be used properly by examining various situations such as the direction of the wind, the flow of the waterway, and the time when the tide

is in or out. Haenyeo gathered the wisdom of the community for a long time to understand the sea. As a result, they learned how to know the type of seafood and the process of growing it up and acquire all about the sea themselves. Haenyeo learn muljil(diving activities) from an early age and do not leave the sea until they can no longer move their bodies. Although they are paid for their work as much as they do in the sea, it is a life-and-death workplace where they have to risk their lives. It is a place where they have to endure the wild waves coming in successively and biting winds blowing . Haenyeos consider diving into the sea as a visit to the "underworld". Occasionally, there is an extremely dangerous situation in the sea or an accident that leads to death.

When the new year begins, haenyeo, who take a risk doing muljil, desperately hope that it a good harvest year in the sea. They pray eagerly to the gods of the sea by performing a gut so that they could gain prosperity and be safe without any danger. When the gut takes place, all the haenyeo in the village regard it as "our day". It is because the rituals wishing to God are a feast for them every year. Throughout the coastal villages, they are surrounded by blue dawn and move busily from the crack of dawn. On this day, the life of the haenyeo is turned upside down, Flashing their flesh, and the life of the haenyeo is expanded.

The name of every haenyeo is called one by one, hoping to bring good luck to them and prevent the bad luck of the new year. Even a small accident in the sea is a big deal, so the safety issue of haenyeo is the most important concern. In addition, they wish the sea field always abundant. The names of these guts are "Yeongdeung-gut" and "Jamsu-gut".



Gimnyeong-ri Jamsugut © Jeju Special Self-Governing Province

The simbang continues to talk about haenyeo's joys and sorrows and their wishes while leading the gut. The simbang asks many gods, including the Dragon King and the ancestral spirits to take good care of the haenyeo because they pray out of desperation as if thirsty people were looking for water. She reminds them that a ship with people is never wrecked, and that hard work always pays off. She does not appreciate the god giving them away their bad luck last year. She mentions the daily life of haenyeo who suffer from the bitter wind of January and February, the hot heat of May and June, and the blizzard of Dongjidal. She says that they diving in the sea as their work place for a living although in summer, hot steam rises up and in winter, their hands and feet get cold, praying and praying for the life to the Dragon King and begs the god to save haenyeo who otherwise would not be saved. She also asks the god to let them avoid being frightened in the sea. She hope that a lot of seafood grows all over the sea, so that they can pick up nets filled with rich marine products. In addition, she warns someone not to overwork and tells someone to be specially careful.

Yeongdeung-gut is a shamanic ritual held between the first and the fourteenth day of the second lunar month to greet Youngdeungshin. It's a gut to wait for the new spring.

The stone statues of King Yeongdeung and Yeongdeunghalmang in Yeongdeung Shinhwa Park, Gwideok-ri, Hallim-eup

Youngdeungshin is usually perceived as "Yeongdeung Halmang (Halmang means 'grandmother' in Jeju dialect)" when the cold wind blows from the northwest in winter, the Goddess of Wind brings abundance into the land and sea. Meanwhile, in the area of Hallim-eup in Jeju-si, Bonpuri, the original story of King Yeongdeung saving fishermen from a one-eyed giant, has been passed down. Yeongdeung-gut was originally a gut closely related to Bonhyangdang across Jeju Island. However, the current Yeongdeung-gut is changing in various ways. Though it is also held in some villages in the middle of the mountain, it commonly takes place in coastal villages as a ritual for haenyeo and fishermen. Each Fisheries Cooperative in each area holds the ritual that is known as the name of Poong-eo-je. Yeongdeunggut is a shamanic ritual held between the first and the fourteenth day of the second lunar month at village shrines in the coastal parts of Jeju Island, to greet the wind god Yeongdeung and pray for safety at sea and a big catch, not only for fishermen but also for the island's women divers who gather conch, abalone and sea mustard.

Jamsu-guts are also held in large and small forms anywhere in coastal villages where haenyeo live. Jamsu-gut means haenyeo-gut. In the past, haenyeo was called "Jamsu" or "Jamnyeo(female divers)", so the name of the gut is also called Jamsu-gut. The haenyeo community of the fishing village is the center, and depending on the village, it is held every year for all day long, or once every few years for 2-3 days with a certain period of time. In some cases where some unfortunate events occur in a row, the ritual could be held irregularly. The period is usually from January to March in the lunar calendar.





Yeongdeung-gut in Gwideok-ri, Hallim-eup, Jeju-si in 2019. From the first day of February to the full moon in February, when Yeongdeung-gut is held, a festival is held throughout the village. Due to COVID-19, this year, the minimum number of people gathered and enjoyed quietly.

Compared to Yeongdeung-gut, Jamsu-gut is for a specific livelihood community called Jamsu (Haenyeo). In other words, Jamsu-gut is a shamanic ritual that in which Jamsu generally pray for the year's prosperity and the safety of the divers to the Dragon King (of the Sea) at the beginning of the year. Yeongdeung-gut and Jamsu-gut show almost the same ritual. Centered on the dragon king of the sea, depending on the history of the village's gut, various gods and goddess, such as Dangsins and Youngdeungshins, are invited and usually progressed over a day. The order of the gut can be divided into Chogamje (song of first invitation), Yowangmaji (greeting for the Dragon King), Jidrim (tossing offerings), Ssidrim (offering of

seeds) and Ssijeom (divination by seeds), Aekmaki (preventing from bad luck), Seonwangpuri (greeting Yonggamsin) and Baebangseon (floating a straw boat). At Chogamje, the god is summoned, and at Yowangmaji, they pray for safety at sea and a big catch. At Jidrim is to toss an offering into the sea little by little after wrapping it in paper.

At Ssidrim, hulled millet is sprinkled all over the sea, hoping that seafood is abundant. At Ssijeom and Aekmaki, it tells participants' fortune and prevents bad luck from coming to them. At Seonwangpuri and Baebangseon, Yonggamsin who took the boat is treated and a miniature straw boat is



Floating Baebangseon off after the Jamsu-gut to pray for a good catch and safety © Jeju Special Self-Governing Province

sent to the sea. Currently, it is rare in Jeju Island to show the connection between livelihood activities and religious rites as clearly as Yeongdeung-gut and Jamsu-gut. Yeongdeung-gut and Jamsu-gut even take on the role in bringing the haenyeo community together beyond prayer for a peaceful and accident-free and abundance of seafood. In addition, these days, when many of the traditional cultures of the past have disappeared, gut is playing a central role in the transmission of Jeju Island's community culture by chance or inevitability. Compared to other intangible cultural heritages, a more collective and powerful transmission is taking place. As a result, the role of the gut is gradually expanded with the functions of the village gut. Even now, more than 30 villages do gut on a large and small scale.

Baebangseon is made by the owners of the houses with the ships, and they are floated directly on the sea. Previously, Baebangseon was loaded on rafts, and When

Susinbang(shaman) prayed and hit, and struck a Jing(gong), people rowed out to sea. After the first raft to move forward released a miniature straw boat, Susinbang sent a stop signal. Then float all of the miniature straw boats from every raft. The first raft that went out was said to have a big catch in that year, so the ship owner caught a pig and held a village feast. 

Bonhyangdang in Seogwi-dong, Seogwipo-si
© Encyclopedia of Korean Folk Culture



'Walking, running, picking up litter'

Plogging to Improve your health and the beautiful Jeju environment

Written by **Lee Hyeon-ju**,
manager of the Jeju provincial Council for Sustainable Development





In 2016, the term “plogging” was coined from the English word “jogging” and “plocka upp”, a Swedish term that means “picking up”. In other words, Plogging is a combination of jogging with picking up litter, but is called Jupging(Jupda, the Korean phrase for picking+jogging). Plogging is an environmental clean-up sports activity where you pick up trash while walking or running, as well as an environmental protection campaign that is spreading around the world as a movement to protect yourself and the global environment. It is said that sitting and standing up to pick up litter is similar to the squat stance, and because you run with a bag of trash, you can burn more calories than simple jogging.

In addition to exercise effects, it is gaining much more attention as a non-face-to-face activity that can be done outdoors for people who have become languidly weak both in body and mind due to the long-lasting coronavirus quarantine.

As you can see, plugging is an attractive activity that can be done alone During COVID-1, but it is not so easy to put it into practice.

To give a tip to somebody who has just nodded, I would like to share information on organizations that are continually engaged in logging activities in Jeju Island.

Walking and picking up litter along the village streets , Jeju Plogging

First, the "Jeju Special Self-Governing Province Council for Sustainable Development" started the first plogging activity in 2019 with the Jeju Special Self-Governing Province and News 1 Jeju Headquarters for the event,

plogging

「Walking and picking up litter, Jeju Plogging」 .

Although the weather was inclement due to the typhoon, more than 200 people, including teenagers and local residents, participated and picked up trash around the Jocheon Stadium by walking or running. In addition, various programs such as the OX Quiz Game about resource recycling and environmental experiences were also conducted.

Last year, due to the COVID-19 pandemic, they conducted a plogging activity with a small-scale participation method instead of a large-scale event. They promoted their plogging activities in popular spots where a lot of Jeju residents and tourists visit, such as Gwakji Beach, Handam Coastal Trail, and Songdang-ri Village Road. This year, it is planned to be carried out downtown in order to inform that plogging is an activity that can be easily practiced in everyday life.

"Clean Olle" to protect health and nature while walking on the Olle Trails

Jeju Olle's Clean Walking Campaign is held at Jeju Olle to pick up trash while walking along the Olle Trails. You can pick up the envelopes at the Jeju Olle Official Information Center or the small Information Center located in each course, pick up trash by type, and throw it away at a designated collection place. The hours you do this is also recognized as the amount of time to volunteering . If you collect stamps for participation more than 8 times, you can get souvenirs. Thus, if you love Jeju Olle Trail, don't miss it!

Marine clean-up activities to protect the Jeju sea, "Beach Clean"

If you want to actively participate in plogging activities to solve the problem of marine debris, why don't you join this volunteer activity?

'Save Jeju Bada' holds "I Do It Alone Beach Clean" events.

Through advance reservations, only individuals or less than 4 people can participate, and tools like beach clean bags for the activities of marine litter clean-ups are lent.

'Diphdajeju' is running the "Picking and Drinking" program. at the cafés around Jeju beaches with which it cooperates , it offers a free drink per person who pick up marine debris and dispose of it in a designated place and post particular photos of the volunteer activity on social media .

1. 2. The 1st 'running, picking up litter' Jeju Logging Event in 2019

3. Jeju plogging with a village community – Plogging on Songdang-ri Village Road in 2020





4. The promotional photo of Clean Olle ©Clean Olle
 5. The promotional photo of Save Jeju Bada©Save Jeju Bada
 6. The promotional picture of Diphdajeju ©Diphdajeju

A little differently, "Bike Clean"

Unlike traditional plogging activities, there are ways to use bicycles if you want more unique experiences.

"Bike+Clean", which is being hosted by 'Purun Bike Sharing', is an eco-friendly travel program that is operated as a corporate training or group program. While travelling around Jeju by bicycle, a pollution-free means of transportation, the participants pick up trash thrown away in the sea, forests, and Olle trails.

Plus, various plogging activities are being actively carried out throughout Jeju to protect the sustainable Jeju environment.

The reason why so many groups engage in plogging activities is that ultimately it gets people to think twice before they throw away rubbish, have a little courage to pick up litter together, or use even a piece of disposable wet wipe, a straw, and a disposable cup.

I hope that these wishes come together to think and practice together and lead to healthier, more beautiful and sustainable Jeju where we live.

As if it seems to question when we had a cold winter, we feel warm spring air in Jeju.

To revive and refresh your mind and body, to enjoy the spring that will be gone soon or to pat ourselves on the back efforts to overcome the COVID-19 pandemic, how about walking, running or plogging this weekend after you put on gloves and a mask tightly and take a bag that you don't usually wear?

Even if it's not a program run by any group, you can start your own plogging at a club that climbs every weekend, on path on Sarabong, where you exercise in the morning and evening, or on the alleyway where cigarette butts are piled up in front of my house!! 🚬

Information on organizations related to plogging activities in Jeju Island

Jeju provincial Council for Sustainable Development

064-748-1021

Clean Olle

064-762-2190

Save Jeju Bada

064-746-0404

@ savejejubada

Diphdajeju

@ diphda_jeju

Purun Bike Sharing Inc.

064-721-0333



Beautiful Jeju Wild Flowers in Oreum

We are going to Tong-oreum

Written by **Kim Seom**, author of children's literature /
Photo by **Kim Seom & Kim Suo**

Children start to run. Cherry blossoms in full bloom like cotton candy open their arms, and the children burst into spontaneous laughter with them. Tong-oreum in April, when the cherry blossoms are splendid, is like an amusement park for a festival in itself. We walk up into the cherry blossoms that stretch out through the atmospheric wooden stairs. The flowers of potentilla and violets smile on the side of the wooden stairs. We also lower our height and whisper tenderly. Thistles squeeze through the cracks of the wooden stairs and pulls up their shoots. Thistle, before the thorns become rough, is perfect for vegetables or salads.

Little thistle, which has a lot of silymarin to heal and regenerate the damaged liver, was a medicine for the poor people.

Is there only little thistle? All nature gives is medicine, and nature itself heals us.

I found a bunch of pulsatilla koreana flowers hiding among the withered and lying silver grass stems. This is the place where Jejudo ladybell quietly bloomed in the last autumn and next to it, the flowers of ladybell and Thunberg's chive were also smiling. I calmly expose and completely capture them in my camera.





Violets are blooming on the road to Tong-oreum.

Tong-oreum, the word “tong” means a barrel in Korean, is a horseshoe-shaped oreum. During volcanic activity, it is presumed that the fiery flow (flow of volcanic debris erupted from the crater) broke a part of the crater and came out of the crater to form a horseshoe. There a summit just 30 meters from the entrance where cherry blossoms are welcoming as five small peaks surround the hollowed Gumburi (crater). The summit is full of silver grass . It is said that the villagers cut this silver grass in autumn and made a thatched roof from it and took their cattle and horses up to pasture there. It used to be a a denuded hill when their horses and cows grazed there, but now it's full of silver grass as they raise them anymore in the pasture.

The wind is not blowing gently. Even in the wind, we exclaim at the stunning scenery surrounding the oreum. After taking pictures of the wonderful scenery, posing among the silver grass, we closely sat in the gap between the wind-blocked and cozy doldam (stone wall) and sandam (stone wall surrounding the tomb).

Jejudians have a habit of leaning on sandam. Even if they get lost in the mountains, they greet the owner of Sandam and lean on it to take a break.

Jeju people bury, protect and take care of their ancestors on farmland cultivated at the corner of oreum.



The scenery seen from the top of Tong-oreum. Tong-oreum is adjacent to the Sinsan Intersection around 1976 Nansan-ri, Seongsan-eup.

When I look at the tomb, I can feel the owner of the tomb and his descendants.

I spontaneously feel a twinge of envy when I see the tomb which is well decorated with a door for the soul to enter and Dongjaseok (a stone statue) by the descendants. Even though it was not formal and roughly piled up in a round shape, some quiet clean and humble sandam like a disinterested scholar's house in Namsangol catches my eye. Sometimes, when I encounter some sandam covered in thorn vines because the hand of my descendants is out of reach, I gather my hands and pray for them with sympathy. Though it is death, we will reflect on various questions about life, the boundary between death and life.

There is a famous tomb in Yeongsani-gol(valley) at the northwest shore of Tong-oreum. It is the grave of Nobi Youngsani, a slave in the family of Ojori Kang. Mr. Kang after the death of his father, asked a geomancer for a good site for burials and wandered for over three months and struggling because he could not find a suitable place for the grave. With the help of his slave, Youngsani, Mr. Kang found a great place and served his father well, and when Youngsani passed away, he buried him next to the tomb. The descendants of Mr. Kang say that Yeongsan have still taken care of his tomb during the ancestral rites. It would be difficult to understand from the perspective of modern people that he was searching for the site of his father's grave for such a long time and his descendants still repay his slave for his effort. However, the traces of the ancestor's thoughts and breath are themselves beautiful cultural heritages and roots.

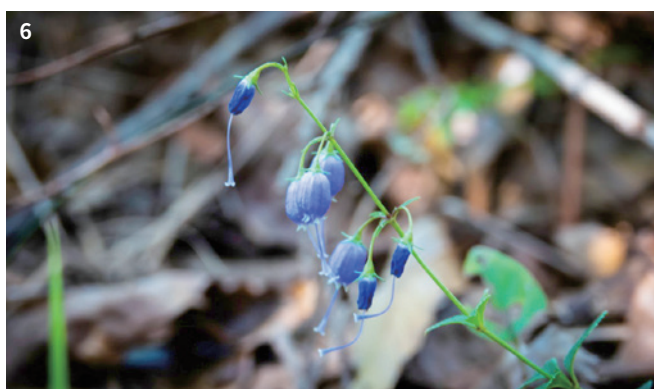

1.fleabanes/2. allium cepa flowers/3. ttakjipul/4. starworts /5. thistles /6. ladybells /7. violets and cinquefoil

The fruit of the barley tree in the spring rain is already ripe. I take a handful of lunch boxes from nature. The children's eyes are sparkling in front of unfamiliar food. I put it in their mouths and a smile lifted the corner of their lips. Nature generously gives us whatever we want. The clean foods you meet in the sea in oreum are like warm dinner made by Mom that welcomes families who have returned from work. A mother's table that heals the hunger in the body and the hunger in the heart. Even for someone who is still hungry after eating in vain, if you eat it, it is a meal table that is a supplement to someone who is in vain, it become a medicine for curing both the body and mind. As we come across cute mushrooms in the spring rain, the children sit in front of them. As soon as I tell them not to touch them, but to just look at them, they stop reaching their arms and keep an eye on them. It is said that when cows and horses became beautiful, coprophilous mushrooms grew up. Like "You could not eat other mushrooms with a mouth that has eaten a coprophilous mushroom" became an old saying, The legendary mushroom is no longer visible.

The sound of spring birds looking for a mate is approaching through the fruits that have not yet fallen. It is Tong-oreum where you can hear the sound of a bush warbler, a titmouse, a ficedula parva and a cuckoo. The bird that has spread its wings and stops in the high sky is a duck hawk. It's called Endangered Species Level 1, but it's a bird that we need to protect due to one of level 1-endangered species. Rather, the bird stands still as if trying to protect us. The children also hold their breath and look up to the sky.

Like birds, we want to tweet and bring out a poem.

The scenery seen from the middle of the road to Tong-oreum. Jeseok-oreum and Dalsanbong can be seen in the distance.



We are going to Tong-oreum

Cherry blossoms bloom in Tong-oreum

We are going to Tong-oreum

Taking pictures in a windy silver grass field

We are going to Tong-oreum

Under the wind-blocked doldam, whispering

We are going to Tong-oreum

Passing the hotdam (sing-stone wall),
gupdam(double-stone wall), and sandam (tomb-stone wall)

We are going to Tong-oreum

Even when the cherry blossoms fall

We are going to Tong-oreum

Even if the wind strikes like a thunder

We are going to Tong-oreum

When thistles grow in the cracks of the stone,

We are going to Tong-oreum

Even on the day when the Jejudo ladybell bloom

Holding hands with children

We are going to Tong-oreum

Of 〈Ham Kke Jekyllak〉,
Kimseom's Jeju Poetry

When the kids recited a line from the poem in advance, they repeatedly recite, "We are going to Tong-oreum."

Carving the poem, we cross a single wooden bridge, and walk around Gumburi. Tong-oreum Gumburi (crater) is full of spring. The yellow canola blossoms and the wave of barley are peacefully harmonized with the newly plowed fields. Tong-oreum Gumburi is attractive enough just with them. Even if there is no standing water or Doksegi-oreum (baby oreum like an egg) like other oreums in the Gumburi, it makes people smile. As soon as we become sunshine of this spring, we are brightening like flowers.

Please come to Tong-oreum on a sunny and windy day. Please run the long, tortuous path to Tong-oreum, where the humming song spontaneously comes out. 🌻



Illustrated by Kim Yeonju

"The Old Future" of Jeju Island, **Batdam**

Written by **Kim Ji-taek**, vice-president
of the Korea Institute for Industrial
Economics and Trade/
Photo by **Editorial staff**

“ Batdam, which are winding and twirling throughout Jeju Island, represents the aesthetic of Jeju with the beauty of its curves. ”

Jeju Island is full of stones and wind. They have intertwined and woven the journey of Jejudian life. The strong, frequent winds and stony soil represent the barren living environment of Jeju Island. Even now, Jeju Island is full of traces of volcanic activity. All parts of Jeju Island, from the mountain valleys to the coast, are full of traces of lava whirling, not to mention Mount Halla and oreum. The volcanic ash soil, where stones protrude from even a little digging and the wind sweeping through the soil almost every day. It is not an exaggeration to say that life on Jeju Island is a battle with them. So is farming. In order to farm here, where there is a lot of wind and high precipitation throughout the year, all kinds of care must be taken to protect the soil from wind and water so that the crops could grow well. That is why Jeju Batdam was born.

The stones of Jeju Island are both an object of overcoming and a natural resource. This is the background of various stone cultures on this island. Wondam is a traditional fishing method, and traditional houses are made of stone. Uldam, or Olledam are used to protect their house from the wind blowing in all seasons.

Sandam preserves the tombs of their ancestors. The wisdom of building stone walls could be obtained naturally by turning the stones scattered around into a resource.

Batdam is built by piling the stones around the edges of the field to prevent strong winds and soil losses and to help the crop grow. However, in terms of the labor force and scale of the past, batdam is different from the construction of a residential area as an indispensable factor. This is because it is not easy to think that the entire cultivated land is covered with stone walls. According to the documentary record, in 1234, when the dispute over the land boundary became frequent, Kim Gu, a Jeju judge, had a stone wall built for a form of boundary by ownerships. But even before that, Batdam would have existed. This is because it is hard to say that this extensive and tremendous work was done within a short term by one judge's decision. Ultimately, considering the origin of the island's agriculture, it is presumed that at some point before that time, Batdam was built and gradually expanded throughout the island as a result of understanding its function.



Jeju Batdam was compared to "Heuk-young" because the long stone walls stacked with black volcanic stone resemble a dragon, and it was called 'Man-ri' since it continued endlessly. That is why Jeju Batdam is called "Heuk-young-mal-li(黑龍萬里)".

22,000km of "Heuk-young-mal-li", the Great Wall of Black Dragon Field walls on Jeju Island have been built up by small communities of individuals or family units. Rather than removing existing stones from the field during cultivation, it is much easier to pile them aside and require less labor.

If you recognize that need, you could instantly get rid of anything. It wouldn't be an overstatement to say that the moment when a pile of stones, called "mudle" that had been neglected in a corner of the field, turned into batdam was a revolution in Jeju agriculture, considering productivity improvement. In addition, the construction of guard field walls under the direction of Judge Kim Gu became the background for the spread of Batdam evenly throughout Jeju. After that, as grazing cattle and horses was carried out for each village, Batdam also took on the role of preventing livestock from trespassing in the field, and was built in more detail. Over a long

period of time after Batdam began to build up, the entire Jeju Island has been embroidered with a mosaic pattern. Then how long is Batdam? One study estimates that the length of Jeju Batdam is approximately 22,108km. 22,000km! The circumference of the earth is about 40,000km, so the total length of Batdam on Jeju Island is longer than half the circumference of the earth. Therefore, it is also referred as "Heuk-young-mal-li(黑龍萬里)". It is named because the black-colored basalt's field wall, Batdam, which is constantly winding and continuing along the fields resembles a black dragon. The black-colored basalt's field walls continue to flow smoothly, resembling a black dragon. "Man-li" is a symbol of an endless length and reminds us of the sweat of the ancestors of Jeju Island. Batdam on Jeju Island, reminding us of a huge picture when viewed from a distance, is an agricultural cultural heritage that contains the wisdom and efforts of the ancestors as its intact form.



Wisdom to overcome the barren environment

Batdam has a crucial function in Jeju, where agricultural management centered on field farming is carried out. It is Jeju Batdam that has been propping up the local agriculture by filtering out strong winds to help grow crops and to mitigate the loss of the topsoil of agricultural land by heavy rain and wind. These functions are still valid, and as long as agriculture continues in Jeju, such functions of Batdam will continue..

In addition to these agricultural values, Jeju Batdam has a value as an outstanding cultural landscape representing the aesthetic of Jeju. Jeju Island is often described as a place where dots, lines, and faces are harmonized. Or, the beauty of smooth curves is also called the aesthetic of Jeju. Batdam, which are winding and twirling throughout Jeju Island, represents the aesthetic of

Jeju with the beauty of its curves. The black color of the basalt Batdam blends with green field and colorful all-season flowers that bloom throughout the year like canola ones and creates picturesque Jeju. If even snow is piled up on the batdam, you encounter an exquisite harmony of black and white that could not be found anywhere else. Batdam, basalt stone wall, creates such a spectacular scene that you could not encounter unless you're in Jeju. Jeju Batdam is also significant in social and cultural aspects. This is in line with the educational values that will be passed on to future generations. Jeju Batdam is a history of life that fought against the barren natural environment and was a real support for survival. Therefore, Batdam provides a glimpse of the pioneering spirit and wisdom of the Jeju people, and is of great value as a unique heritage that contains the journey through which people and nature coexist and live.

Batdam is also a valuable resource for Jeju tourism. Based on its unique scenery, it is positioned as the main theme of cultural tourism and rural tourism. That is not all. Jeju Batdam is piled up in a continuous curve, so it hardly collapse. However, if one place collapses, the attached stone wall also collapses. In order not to collapse, Jeju Batdam has to stand shoulder to shoulder with each other, so it is perhaps a symbol of the will and cooperation



Woljeong-ri seen from the sky. Batdam, which connects the boundaries of the fields, continues endlessly.



Batdam built along the waterway © Kim Ji-taek

of the Jeju ancestors who pioneered the barren environment with tremendous effort and patience. Above all, Batdam, which contains the wisdom of Jeju people, is a cultural product that contains the will of our ancestors to protect crops and soil beyond the means of dividing the boundaries of the land.

Between shabby and sturdy things

No special craftsmen or experts are required to build Batdam. Without the help of them, you can just stack the stones so that they fit together well. It is a stone wall with a very simple structure that can be easily restored even if it has collapsed and needs repair. However, it does not mean that anyone can build Batdam properly. To pile stones proficiently, you need a long experience of watching and learning the process of building Batdam. It means that it requires a method of laying the underlying stones, the technique of stacking the stones and the sense of turning the stones around to look at them and putting them down vigorously

if they fit together. This is work that requires skilled technology accumulated with experience that must be built up to match stones and stones while creating certain gaps in consideration of their relationship with wind rather than special knowledge or skills. In addition, the stones used are not only large stones, but also stones of various sizes and shapes like small, flat, angular, or round ones because each stone has its own function.. Each small stone is difficult to withstand the wind, but they act as a seam to each other, creating a new solid wall.

Batdam, which looks very shabby, demonstrates the solidity that rarely collapse even under strong winds due to the shape and friction of the stone, as well as the hole between the stone and the stone. Batdam is a streamlined shape that is well resistant to wind blowing and its frictional force increases due to basalt with many pores. in more detail, thanks to many small holes of basalt, the resistance received by Batdam decreases, which lets wind easily escape, so prevent Batdam from crumbling. It is the secret of Batdam, standing firmly against the many winds over the years. Batdam in Jeju Island is divided into Oedam, Jeondam, Jatdam, and Jobgupdam according to the shape of the pile. Oedam is a common form of Batdam stacked in a single line. However, the shape of Batdam varies widely depending on the topography of the field. If there is rock mass, it is piled on top of it, and in the lowlands, it is piled like a ledge. In a cleared field, Jobgupdam is founded where large stones are raised again after small stones are first densely stacked on the cut-off area that becomes the boundary. Jatdam reveals the warm heart of caring for neighbors who walk by undeveloped land. In this way, Batdam embraces the ever-changing time that they have been farming in the face of Jeju's natural environment.

Batdam is the “old future” of all Jejudians

It is said that it has been a long time since Batdam was built, but there are a lot of batdams that are not. In the days of Jeju 4 and 3, Batdam was demolished in the middle mountain villages to build a castle. The field walls were left behind, so they could be piled back after the harsh times. Everyone knew the function of

Batdam, so they did not refuse to do that laborious work. That is not all of the only history of Batdam that has been with the lives of Jeju people.

The vital energy of Jeju Batdam continues along with agricultural activities that continue to this day. Until the 1960s, Jeju Island had grazed cattle and horses in mountains and fields, and agricultural activities were self-sufficient through crops such as barley, joe, and sweet potatoes, along with livestock farming. Therefore, until then, the Jeju Batdam had not changed much. Recently, however, the appearance of Batdam has changed significantly. With the mechanization of agriculture, changes in cultivated crops and various developments, the change is remarkably accelerating.

Nevertheless, Batdam is still positioned as a representative cultural landscape of Jeju. Batdam, which continues its function despite the rapidly changing trend of the times, is a cultural heritage that we must protect throughout. This is because it is a touchstone that can read Jeju's yesterday, today, and tomorrow. Because of these valuable values, Jeju Batdam was designated as a national

agricultural and fishery heritage in 2013. The following year, it was registered as the “FAO World Important Agricultural Heritage (GIAHS)”. The value of Jeju Batdam is recognized internationally. As Jeju Batdam has various values, it is part of an effort to secure sustainability by properly preserving, managing and using them appropriately. By designating the Batdam Village and holding the Batdam Festival, we are trying to preserve Batdam and to inform the originality and excellence of Batdam culture, but it is only a small beginning. Now the task is for all the Jeju people living today. It should start with realizing that the value of Batdam is in close contact with our own lives. We must desperately accept that the damage and disappearance of Batdam is gradually destroying the foundation of our lives. Regardless of anyone who built it, Jeju Batdam is the ‘old future’ of all of us.

Spring has come again over the silently standing Batdam, and canola flowers have bloomed in yellow again. 



Photo Zone, Jinvillebatdam-gil, Woljeong-ri, Gujwa-eup, Jeju-si

A Jeju
woman
who upholds
the spirit of
Jeju Island,

Yang Eui-suk



Written by **Kim Yeon-ju**, curator of
Cultural Space <Yang>
Photo in courtesy of **Space Yenar Jeju**

One day, when the warm sunlight of early spring calmed the cold wind, I headed for Jeji-ri. This is to meet Yang Eui-suk, a director of Space Yenar Jeju who is well known as a member of the KBS program, TV Show Authentic Antique Masterpieces. I have arranged an interview with her at Space Yenar Jeju, the Jeju craft museum & gallery, in Jeji-ri, which was opened by her at the end of last year. Upon entering the main gate of Space Yenar Jeju, plum blossoms in full bloom among the spacious gardens announced spring, and the crafts placed here and there in harmony with nature made us feel ancient atmosphere. The interview began in front of Jeju bandaji(wooden blanket chest) inside the exhibition hall full of folk art.

You've been in charge of a major role recently. You've been elected the 26th president of the Korea Antique Association. I heard that it is the first time for the association to elect a female president.

Yes, I feel a huge responsibility on my shoulders. The Korean Antique Art Association is the only Korean antique appraisal agency recognized by the Cultural Heritage Administration. It's already been 50 years old since it was founded in 1971. I think there would be a lot of work to be done with a sense of mission in the future at this time when It's time to be reborn in many ways. I would have a lot of work to do. In fact, there are about 500 members now, but in the past there were over a thousand. There were about twelve members of the Association of Antiques in Jeju as well, but now there is no one. In the future, the Jeju Ancient Art Association must also revive. Dealing with art is totally different from a business that makes a profit by buying products cheaply. If you do not have a heart to cherish and value antiques themselves, you cannot maintain it for a long time. Not only is the fairness of emotions essential, but also I have to be interested in the communication and well-being of the members who have been walking along the same path. Truly, I will do the best I can.



You majored in arts and crafts at graduate school without becoming a teacher after you had graduated from college of education. Was there any particular reason for that?

I received a huge benefit from my high school, Jeju Girls' High School. Soodo Women's Teachers College provided a four-year scholarship for one student recommended by the school. Luckily I went to the college after I was proposed by my school. As soon as I graduated, I taught students at my alma mater for a year. One of the terms of the scholarship agreement was that I had to teach at my alma mater for a year after graduating from college. After fulfilling the promised condition, I went back to Seoul to go to graduate school. At that

Space Yenar Jeju located in Jeju Culture and Arts Village, Hangeong-myeon, Jeju-si



"Jeju Sale", like the hostess of Jeju Jeongji (kitchen)

The collection of the sides of pillows with traditional embroidery in various colored threads displayed one side of the exhibition hall.



time, Son Dong-jin, a professor of the Department of Living Arts of Soodo Women's Teachers College, recommended me to study art. When I think about the bonds I made in my life, the special bond with him was precious. As the college allowed its students to change their major, I applied to Hongik University and I got accepted to the Department of Living Art. I felt like the door to the world was open. I had so much fun in graduate school.

You changed your major and went to graduate school with a really special opportunity. So while you were studying crafts, you became interested in folk art.

Ye Yong-hae, who published a number of series in the Hankook Ilbo newspaper was the first person to coin the term, A Living National Treasure. When he was a member of the Hankook Ilbo editorial board, he went all over the country to see all the folk goods and crafts and helped designate a Living National Treasure. In graduate school, he gave a lecture on folk crafts, and while listening to his lecture, I was greatly influenced by him. When I wrote a dissertation, I chose him as my academic adviser. I became more immersed in folkcrafts by studying Jeju Gwe(wooden chest) and writing the dissertation. At that time, plagiarizing a master's thesis from other materials prevailed among graduate students. But I measured the chest, made rubbed copies and interviewed the owner with prepared questions like "How long have you had it?" I even researched its history. Although I didn't write it well, the professor at Hongik University complimented me on my thesis, saying "You are wrote the thesis best. the best!" when I came across him on the street.

You have been running Yenar, an antique gallery in Seoul for a long time. How did Yenar start?

When I was in graduate school, I also attend a lecture on an introductory course in crafts by Lee Kyung-sung. As soon as I graduated, I became a lecturer at Kyung Hee University at the age 26 with his help. The harder I worked hard on the lecture, the more lectures I gave. I gave a lecture in the morning, went to the hospital in the afternoon, and the next day, I gave birth to my baby and came back to school in 18 days to give a lecture again. But one day, someone who was one or two years younger than me became a professor after studying abroad. I was so shocked that I considered I had to do my job for myself. It's worthwhile to enlighten students, but I thought being a lecturer was not my identity. At that time, there was little concept of craft and few craft works. Thus, I thought it would be nice to make a craft work and run something like a craft gallery store. But my husband strongly opposed it, saying that it's a business, so you shouldn't do it recklessly. Then one day, he told me to give a try after he met with someone who used to run a museum. I bought duju during the time when the rice box was popular, and I put rice in it and used it. I bought antique dwiju (grain chest) to keep rice at home during the time when the rice box was popular. Also, there was a bandaji. I enjoyed the time when I bought something pretty and hung it up. So I started Yenar.

You are also busy with your career in Seoul, but you opened Space Yenar Jeju, the Jeju craft museum & gallery, on Jeju Island. I think there seems to be a special reason.

I started in a humble way last fall. By primarily exhibiting antique Jeju art, I would like to contribute to helping viewers learn and keep

its value. As time goes by, antiquities keep disappearing and become more and more precious. I think that if we did not preoccupy and keep the must-have of Jeju Island, Jeju Island would eventually become another Jeju Island, which belong to others, not ours. It has been about 15 years since I paid great attention to the folk crafts of Jeju island. To be honest, those days I researched Jeju folk art and crafts and wrote some articles on them, but I didn't recognize the worth of them and the superiority over others from other regions. I realized that it was important and valuable, but I learned that it is aesthetically unique and excellent after a long time that I saw other local folk art and crafts. If you did not know other local things, you could not tell the unique and superiorities of Jeju traditional crafts. For example, it

is emphasized that Jeju bandaji has good quality because it is made of zelkova, but there is a lot of antique furniture that is made of the same trees on land. However when I came to Jeju Island, I looked deeply and found that zelokva trees in Jeju are really excellent. In fact, Jeju Island has little soil and a lot of stones. The zelokva trees grown in a place like Jeju are very different from others on land. As you compare it to others and notice the differences, you can discover the excellence of Jeju folk crafts. Jeju people say that it is good only because it is from Jeju or it is ours, but the perspective is not convincing. You have to see a lot of other local antiques to see Jeju Island's antiques. For this purpose, Space Yenar Jeju holds the exhibition of bandaji from the eight provinces of Korea, focusing



Each of the art craft exhibited at Space Yenar Jeju reveals their beauty in simplicity.

on Jeju bandaji around the end of April. If you visit and take a deep look with affection, you find the difference between Jeju bandaji and other ones.

Specifically, What are the characteristics of the aesthetic sense of Jeju Island's antique works?

The aesthetic sense of Jeju Island is unique. At first glance, the ornament in Jeju Bandaji is similar to that of Jeolla Bandaji, so you could not tell which one is from Jeju Island or from Jeolla Province. The more closely you look at them, the more you notice that there are some differences between them. The ornaments had to be ordered and brought from Jeolla-do. To make matters worse, they were not cheap, so later they were made on Jeju Island. The most basic decoration of Jeju's dandji has a fan-shaped patten with the Buddhist emblem (卍) engraved, a bat pattern, a chrysanthemum pattern, and a diamond pattern. The thickness of the ornament very. If there is no blank space with poor decoration design, It looks complicated. However, even if Jeju Bandaji has no space, it does not feel that way. This is the characteristic of Jeju Bandaji, and it feels like blew my mind. It looks like the women of Jeju.

You always evaluated the value of a work of art on TV Show Authentic Antique Masterpieces, but



Jeju Gwe (65.5×30.3×48cm) and Jeju traditional decoration with with the Buddhist emblem (卍)

I think any folk goods are valuable regardless of the price.

Folk products can represent the people of that era. Though they made things because of their needs, but their thoughts and spirits melt into it. For example, there was Meoktong used by a carpenter. Among the carpenters, the chief carried it. It ranges from really simple to extravagant ones. That is a symbol of the carpenter, so they made it for themselves. So we can imagine what a carpenter is like when we see his Meoktong. There are some beautiful things because they are so simple and humble. Some old products that were made by ordinary people a long time ago without any skills are very simple and aesthetically pleasing to modern people now. nowadays. They have sincerity. Korean folk products with such a sense of

Exhibition information
Jeju Gwe and Paldo Bandaji Exhibition

Place

Space Yonar Jeju (36, Jeoji 14-gil, Hangeong-myeon, Jeju-si)

Period

May 1-June 27, 2021

Exhibits

About 50 pieces of Jeju Gwe and Paldo Bandaji

Inquiry

064-772-4280



intrinsic beauty began to disappear and collapse during the Japanese colonial period. Korean craftsmen started to decorate a lot because they had to sell their crafts to Japanese people. I think that folk art is very important because it represents the people and the society. A common example is that even a collector who likes pottery has good folk goods, and when he needs money, he sells pottery and never sells folk goods. Folk products become more valuable as you possess them over time. They are crucially important because you can get to know the life of the old days and the society at that time while appreciating folk products.

These days, interest in antiques and cultural assets has been increasing. Please give some advice to students studying antiques.

The appraisal of antiques is essential. There is no study as good as watching expert appraisers appraise collectibles and antiques a lot. For instance, if you look at someone's face, no matter how much makeup they put on it, you could roughly estimate their age. It's because you always meet strangers and see their faces in everyday life. The same goes for antiques..You have to go and touch them as much as possible. You need to read a lot of books and ask make questions. It is much more helpful for you to do a lot of on-site study. I am very glad that young students sometimes come to the gallery I run. I want to show them anything more.

You have been walking the path of becoming an antique art expert for nearly half a century, but this year it seems to be even busier. I am curious about your future wishes and plans.

I'm writing my reminiscence and experiences I had while working in the field of antique art. Rather

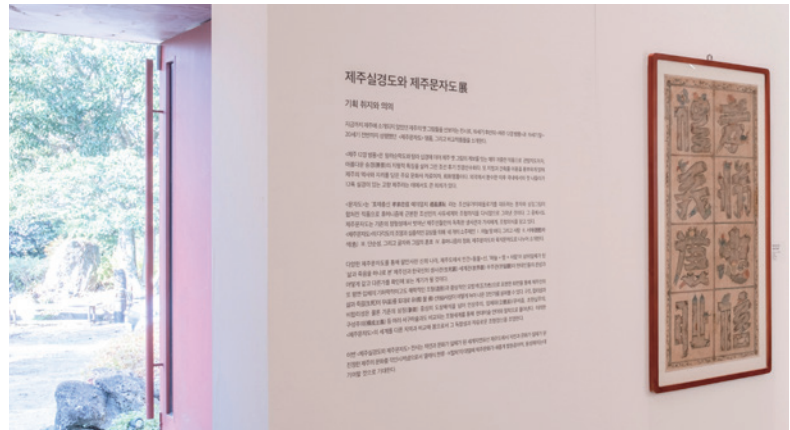

than writing a book, I feel like I am doing old homework myself. I was born in Jeju and have not done much, but I think I have lived with too much benefits. I am always grateful. I hope that even if I could not pay back, my past experiences would be of little help to our hometown, Jeju, and even in the field of antique art. People who know and enjoy culture properly are said to be the owners, but I want to do my best so that more people can feel the charm of our antiques in their lives. In particular, we sincerely hope that Jeju Island becomes the Korean cultural city with Jeju's unique identity. Even in a barren environment, there are enough cultural nutrients accumulated over the years. 🍷

Photo of the exhibition <Jeju Silgyeongdo and Jeju Munhwado> in commemoration of the opening of Space Yonar Jeju. If you visit the museum, you can see Jeju Munhwado, which is currently on display.

Meet Jeju Architecture by Kim Joong-up, a master of Korean modern architecture

Written by **Kim Tae-il**, professor of Department of Architecture, Jeju National University



Architect
Kim Joong-up

Kim Joong-up, who is called the master of Korean architecture along with Kim Soo-geun, the architect who designed the Olympic Stadium, was born in Pyongyang in March in 1922. He graduated from Pyongyang High School, and studied architecture at the Department of Architecture at Yokohama High Institute of Technology (now Yokohama National University). After graduating cum laude in December 1941, he was in charge of special housing design in 1944 under the direct control of the chairman of Choseon Housing Administration. In 1946, he was in charge of designing for the U.S. military construction, and he became a full-time lecturer at the College of Engineering at Seoul National University, where he lectured on architecture and urban planning. In 1952, he participated as a representative of Korea at the 1st World Artists Conference hosted by UNESCO in Venice, Italy. In Venice he met Le Corbusier by destiny and went on to work at the Le Corbusier Institute of Architecture in Paris for three years and two months from October, 1952 to December 25, 1955. In March 1956, he finally returned to Korea and began to work actively in domestic construction. Kim Joong-up, who had established modernism in Korean architecture, passed away on May 11, 1988 at the age of 66. The representative works of Kim Joong-up include the French Embassy in Korea and the old main building of Jeju University.

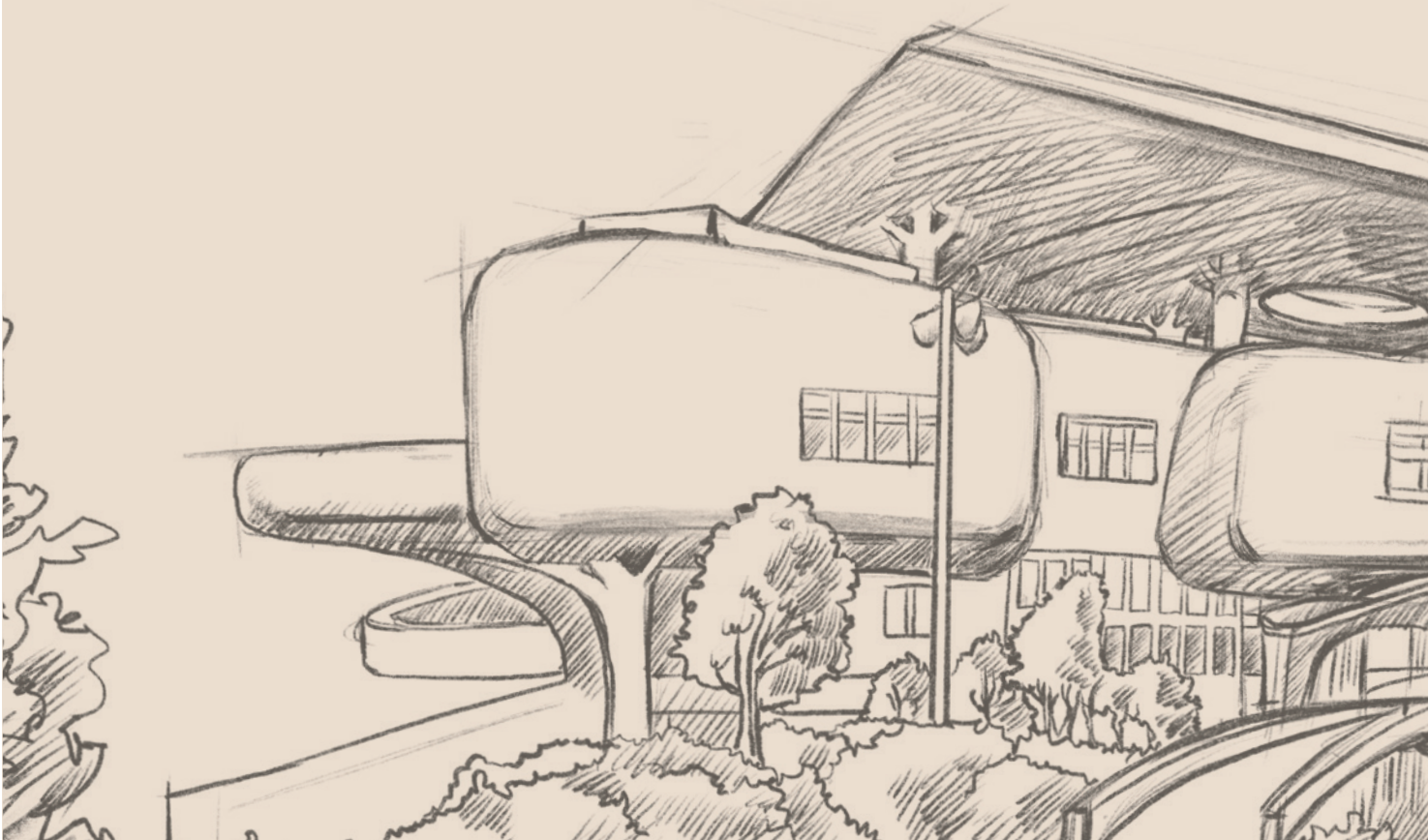

Destiny, the meeting of the master of Korean architecture and Jeju

The small history in the main building of Jeju National University

On the cover of Kim Joong-up's autobiographical collection of <Architect's Light and Shadow> (Yulhwadang, 1984), pictures of the French Embassy in Korea and the old main building of Jeju University are respectively posted. This indicates that they are his representative works which contain his soul and passion.

Among them, the former administrative building of Jeju University is a representative work in Jeju that thoroughly applies the rules and methods of Le Corbusier, while considering the local conditions adjacent to the sea, and harmonizing space and location.

In order to explain the background of the former main building of Jeju University, it is necessary to briefly describe the history of Jeju National University.

The early campus of Jeju University started as a provincial Jeju elementary school (using Jeju Hyanggyo as a temporary facility) in June 1952, and purchased the building and land of Korea Leather Co., Ltd. and used it as a school facility. Afterwards, the site was

French architect Le Corbusier

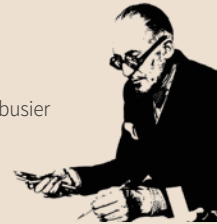

relocated and used for new construction and In March 1962, it was promoted to a national university, which was a long-awaited project.

After the inauguration of Moon Jong-cheol, dean of Jeju National University on January 18, 1961, the plan for expansion of facilities began in the long-term perspective as the transfer was promoted to the national government. Since the Yongdam-dong campus is adjacent to Jeju Airport and the sea to the north, it is difficult to expand facilities. Thus, Yongdam Campus started the work of deciding the policy to be utilized mainly by the Faculty of Law and selecting an appropriate site. At that time, by the relationship between Moon Jong-cheol and Kim Joong-up, the former administrative building of Jeju National University, a representative building in the Korean architectural world, was born. In addition, architect Kim Joong-eop participated in the establishment of the campus plan of the Faculty of Agriculture and Fisheries relocating to Seogwipo, and also designed the building of the Faculty of Fisheries, leaving another monumental work in Jeju.

Illustration by Mike Jeong





The late Kim Joong-up (1922~1988),
Photo in courtesy of Kim Joong-up
Architecture Museum

The representative work of Jeju's modern architecture, the former main building of Jeju National University (Yongdam campus)

Originally, the main building of Jeju National University was going to be built on October 15, 1964, with the first floor (119 pyeong) as a student center, the second floor (191 pyeong) as a library, the third floor (193 pyeong) as an administrative office and a professor's research center, and the fourth floor as a folk museum and the construction started on October 15, 1964, and it seemed to proceed smoothly. Originally, the main building of Jeju National University was built on October 15, 1964, with the first floor (119 pyeong) as a student center, the second floor (191 pyeong) as a library, the third floor (193 pyeong) as an administrative office and a professor's research center, and the fourth floor as a folk museum. However, on March 15, 1967, the headquarters, libraries, and department offices were established after only a part of the construction work was completed without the completion of the old main building of Jeju University due to insufficient budget support. The construction of the new building was completed in 1970, six years after the inauguration of Kim Gye-yong, dean of Jeju National University, but the design was changed during the construction and the student center on the first floor was completely scrapped. The old main building of Jeju University is a representative work in which the rules and methods of

Le Corbusier are thoroughly applied, but the spatiality and the place are harmonized with consideration for local conditions. Le Corbusier's five principles of modern architecture were appropriately applied to the composition of elevation and plane space.

Each floor plan allowed walls to be separated from the pillars to form a free plane, as well as a free elevation. In addition, a partially



Jeju University campus viewed from an aerial photograph in 1967. The U-shaped building above the photo was used as a school facility by purchasing the building and land of Korea Leather Co., Ltd., and the building below is the Yongdam Campus of the Faculty of Law, which was relocated on top of the current high school affiliated with the College of Education. The old main building of Jeju University and the main auditorium are clearly visible.

fragmented but three-story continuous window, a free elevation by the outer wall of the second and third floors separated from the columns, and an outer column supporting the three-story protrusion of the right side had the function of a piloti. And the rooftop's open-air stand is a variation of the rooftop garden.

While applying the functionalist rules and methods of Le Corbusier, he tried to convey a formative image as if he were considering the local climate and surrounding landscape and emphasizing the place and spatiality. The first and second floors were separated from pillars and walls, and the mass of the third floor, which was used as a professor's lab, has a simple structure, so the mass on the third floor is like a flying aircraft or a floating ship. In fact, the site of the old main building of Jeju University was a field close to the sea, and at one time it was used as a military aerodrome for the Japanese military. When viewed from a distance, the old main building looked like soaring skyward. Perhaps he was conscious of the image of the site being bordered by the sea and Jeju Island being an island. Moreover, the geometric curves of the porch with seashells spread out and the rear ramp connected to the second and third floors were reminiscent of the image of seaweed, and could be understood in the same context as the vitality of the sea and the dynamic image of Jeju Island. It can be said to be an architectural textbook that contains Le Corbusier's architectural ideology combined to fit Korean sensibilities



- 1, 2. Front and rear views faithful to Le Corbusier's architectural language. There were many opinions to preserve the old main building of Jeju University in May 1995, but it was demolished due to problems such as difficulty in management and repair and disappeared into history. ©Jeju Tourism Organization
3. The geometric shape of the rear slope © Kim Joong-up Architecture Museum

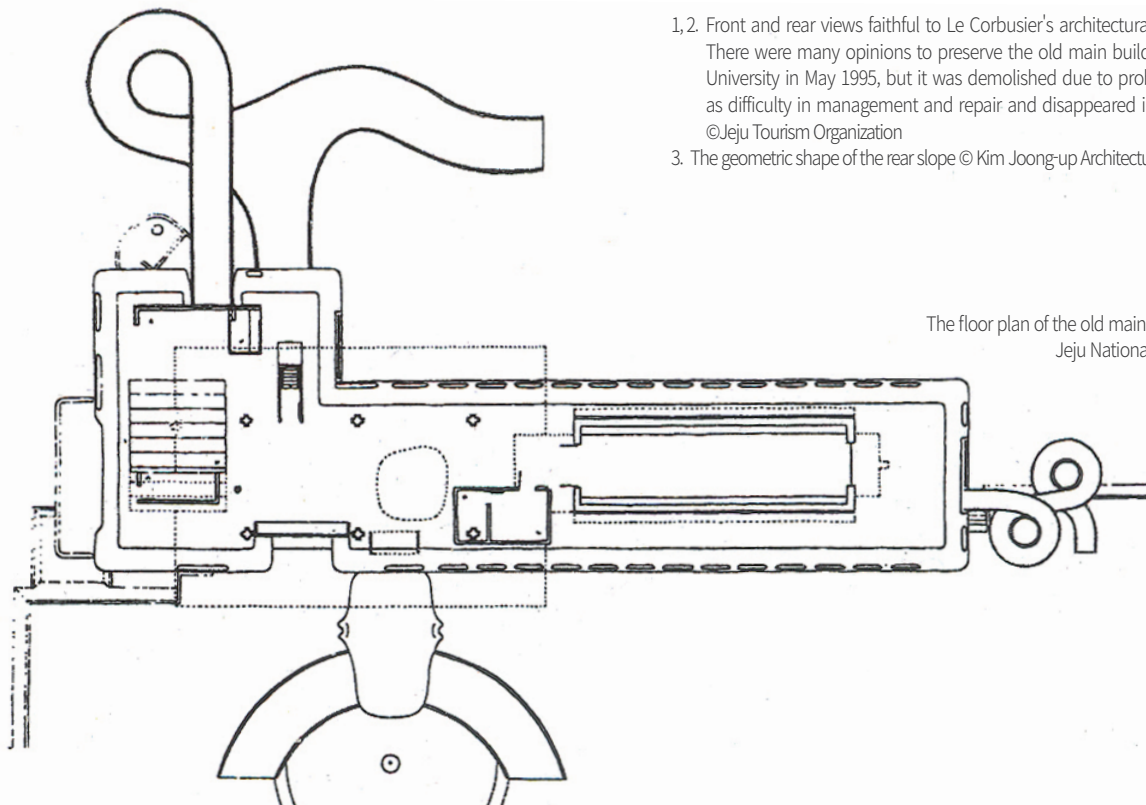

The floor plan of the old main building of Jeju National University

Le Corbusier's architectural language implemented at Seogwipo Campus

As they faced difficulties due to various circumstances while planning the expansion of the Yongdam Campus in Jeju City, the Faculty of Agriculture and Fisheries established a policy to move only departments in the natural sciences to Seogwipo.

The relocation of the Faculty of Agriculture to Seogwipo began in earnest in early 1961, a year before Jeju University was transferred to the national government, and in February 1962, just before the transfer of the national university, a site of 71,938 pyeong was secured at 1510 Donghong-dong, Seogwi-eup. Even after the relocation of the Faculty of Agriculture, expansion of facilities continued, centering on affiliated facilities. In 1965, a total of facilities, 131 pyeong was built, including farm managers,

chicken houses, pig houses, and cows, and 93 pyeong including laboratory animal breeding rooms, livestock managers, and farm warehouses were built. The basic facility plan was designed by Kim Joong-up and completed in January 1964 by Dongbang Gongyeongsa in charge of construction. In particular, the main building of the Faculty of Agriculture was not very large, but the facade design including the opening was unique. It was a refined structure that made the whole building feel profound due to the structure of the first and second floors as if they were separated and the use of Jeju stone on the first floor. Plus, the Faculty of Fisheries was built in 1488-1, Donghong-dong, Seogwipo-si, which is currently being used as Seogwi-jungang Girls' Middle School by expanding facilities to the south of the Faculty of Agriculture site. There is no accurate record, but looking at the old photos of the main building of the Faculty of Fisheries, it seems that a three-story modern building was newly built, but the appearance of the building on the right was demolished due to expansion and renovation. It was used as an agricultural college building, etc., and was incorporated into Yongdam Campus, and ownership was transferred to the Office of Education, and is currently used as Seogwi Jungang Girls' Middle School. Currently, the remaining buildings are in the form of an I-shaped arrangement, and additional functional buildings are connected to the side due to expansion and renovation. The main building of the Faculty of Fisheries is symmetrical and has four different elevations, and the vertical element is emphasized in the front. The left side is decorated with a louver, which is the architectural language of Le Corbusier, arranged horizontally or vertically with narrow plates at an angle and at regular intervals. In addition, the structure of the long protruding structure of the central entrance and the structure of the staircase that seems



4. The general view of the main building of the Faculty of Fisheries at the Seogwipo Campus of Jeju University, which is currently being used as Seogwi Jungang Girls' Middle School.
5. The louver on the left wall with a strong projection of Le Corbusier's architectural language

to be separated from the ground are unique. In other words, it is a building that reflects the simple and functional elements found in modern architecture, and each exterior has a different elevational element. Elements such as protruding windows and pilotis that can be seen in Le Corbusier's work can be glimpsed, and it is composed of a simple yet understated facade.

Furthermore, the stairs in the interior space are integrated with the external vertical wall to provide a simple yet concise structural beauty, free and intense formativeness separated from the railing, and in contrast, the three handles are designed in a harmonious manner in structure, format, and function. It feels like a piece of artwork.

Architecture is a culture that goes beyond building structures

Architecture could be said to be a construct that has an important meaning in constructing a living environment and a result that has been accumulated over a long period of time. Due to this, architecture is called "architectural culture" as it has a strong function as a symbolic structure and asset that reflects the

times, historical and cultural characteristics of the country and region, beyond the function of a simple physical structure that avoids rain and wind. I wonder if it is a good time to consider the restoration of the old main building of Jeju University, the Jeju work of architect Kim Joong-up that shows a cross-section of Korean architectural culture and representative Korean work. Through the restoration of the demolished buildings, it is thought that the possibility and meaning of various uses can be found. It would be possible to use it as a history museum of Jeju National University, use it as a history museum of Jeju Island, and use it as a Jeju Architecture and Culture Center. Since the 1960s, the works of many Jeju-based architects have remained and have been accumulated as commercial buildings related to development projects. Now, architecture has begun to be recognized as a cultural measure representing the culture of this era, and discussions on new tourism commercialization based on architecture are also being taken up. Considering the value of the old main building of Jeju National University as a representative building of Korean architecture and the location of Jeju Island, I think various ways to use it through restoration are sufficient. 🌿

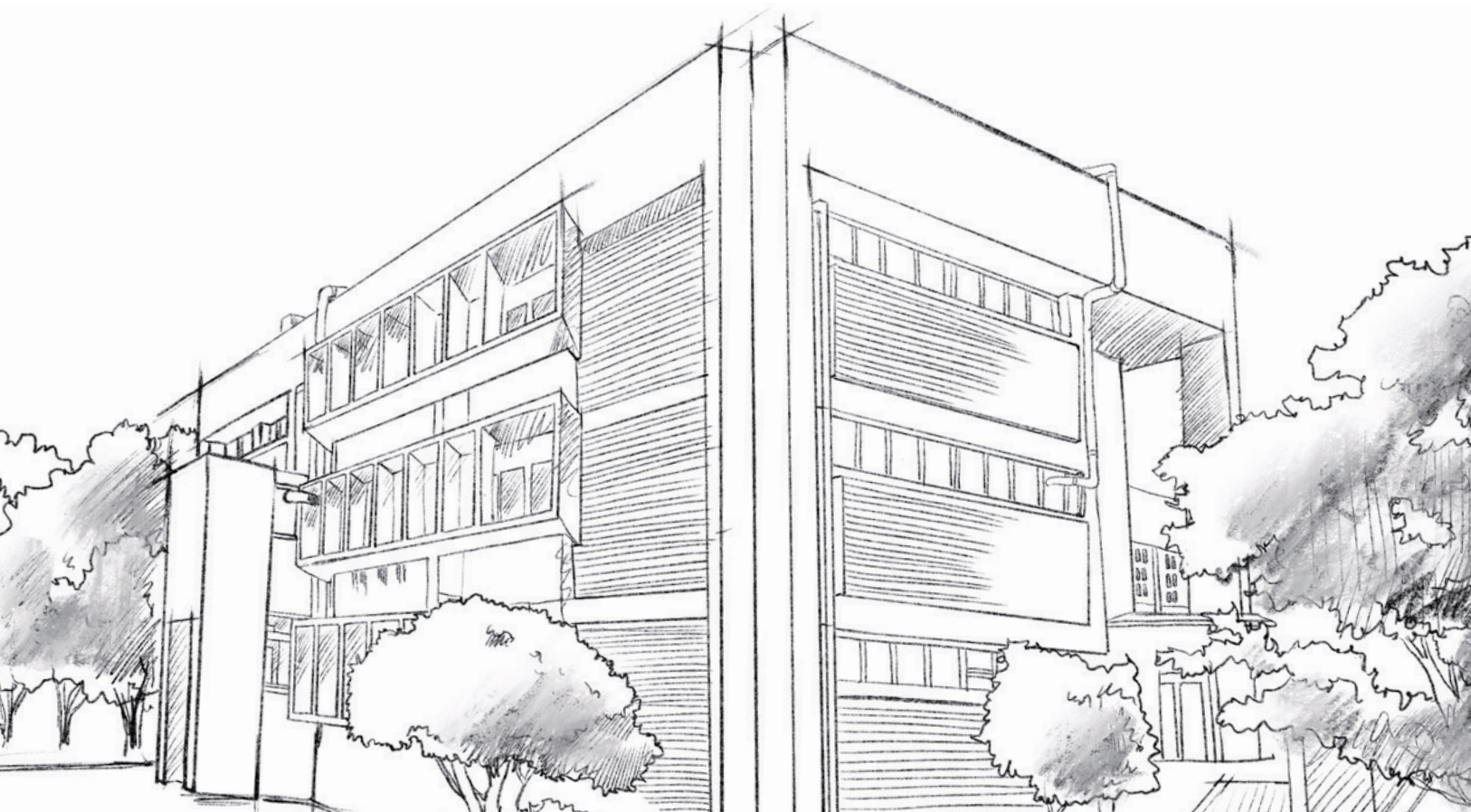



With eight legs giving you strong energy, Mung-ge-juk(Octopus Porridge)

Written by Kang Jin-hee, author /
Photo by Editorial staff



The habit of gastronomy evolves from the relationship of affection for the person with whom you share food. Is there any expression of love that is as honest as food? There would be no other vehicle on earth that brings loved ones together in one place as much as food. Because of this honest love effort that someone has done for the loved ones, delicious foods exist in the world transcending time and space.

As always, in the space of a house on earth, the effort of love flowed to the family as if it were an immortal time. And the agent of that effort is mainly a mother. Among many mothers in the world, the mother of a Jeju haenyeo, who directly dives into the deep blue sea with her bare body, comes out on the ground carrying food ingredients that are good for her family. The sea is a field and gopang (food storage) for a Jeju haenyeo mother who collects seafood from the sea with her bare hands holding tewak and golgaengi (homi) without any equipment for the family's livelihood and daily food. Among the seafood harvested from Haenyeo's Sea Gopan, Mung-ge-juk (porridge) made of octopus is a nutritious and gracious sea nutrition food that energizes the body as it is called Jeju Haenyeo's health porridge.

Eight legs full of vitality



Since octopuses live all over Korea, the names of each region are different, such as large octopus, blood octopus, true octopus, stone octopus, and Japanese octopus. However, Jeju dol octopus, which boasts the best taste in the country, has an interesting Jeju language name called Munge (mainly in the east of Jeju) or Mulkkoruk (mainly in the west of Jeju). It is said that octopuses are caught after Ipchun (beginning of spring) passes, and Jeju octopus is in season from November to April of the following year. An octopus is a mollusk with intelligence as intelligent as a puppy, as much as in its Korean name, Mun Eo (文漁), one of the two letters means literature. An octopus has about two-thirds of the neurons that make up the nervous system. An adult octopus has around 280 suckers per arm that with cells that detect chemical substances, find out whether the object it touch is a prey or an enemy, and even feel the taste of its prey here. The powerful strength of these suckers can keep sharks locked up, which has the power to prevent even sharks in the sea, so you can find out whether the object you touch is a prey or an enemy, and you can feel the taste of the object being prey here. Octopuses have brains all over their bodies. It's like a sea general with both intelligence and martial arts. Perhaps that's why old adults believed that eating octopus is good for brain health, and frequently put octopus in their children's mouths for the sake of their children's clarity. In fact, octopus contains a large amount of EPA and DHA, which has a good effect on brain development. In particular, octopuses are known to be the most abundant in taurine among mollusks. Taurine is a type of amino acid that is excellent in relieving fatigue, and it has a function of normalizing blood pressure and clears blood and gives elasticity to blood vessels. It reduces blood cholesterol levels to prevent atherosclerosis and heart attacks. It helps prevent and improve diabetes by promoting insulin secretion, helps to form a retina, and is also effective in preventing vision loss. Moreover, it is rich in protein with low calories and has little lipids and sugar, which is good for digestive disorders, making it the best food for diet foods.

Mom's support for the family, Jeju haenyeo, Kim Young-ae's mung-ge-juk

Kim Young-ae, who catches an octopus hidden under the sea stone with her hands for her son, who often has nosebleeds, and cooks it for her family, is also a mother who is one of Jeju haenyeo. She started muljil (refers to their diving activities without equipment) with muljil expedition to Anheung Port in Geunheung-myeon, Geunheung-myeon, Taean-gun, Chungcheongnam-do, in her early twenties, said that she learned how to cook mung-ge-juk over the shoulder of her mother-in-law, who had been a haenyeo for a long time. Whenever she wants to give a cheer to her family with her heart, she makes it for his family without hesitation. Despite his indifferent remarks that his porridge-loving son wants to eat porridge, she always cook the porridge for him. She is always ready to cook mung-ge-juk for the family. "There is a saying that octopus eaten during the New Year is a health medicine. It lightens your legs and keeps your blood clean," she said. In Kim Young-ae's kitchen, which was set to cook the porridge, not only octopus, but also palm-sized abalone and cute chubby Obunjagi, and sea urchin were waiting for us after being prepared for mung-ge-juk. Ah! Is there an opportunity to indirectly enjoy the kind of extravagance that only the haenyeo family can enjoy? Just by casting a side glance, you feel the the love of Jeju Haenyeo's mother, who generously brings the entire sea of Jeju to the family table and makes it abundant. Although the boiled water with an octopus itself is a remedy or a supplement, Jeju Haenyeo's mother's mungge porridge, which is boiled with plentiful ingredients, time and a lot of care, couldn't be better. Mung-ge-juk to give a resilient boost to family members who have been drowsy in the spring sun. It's a moment when you envy them endlessly. 🍲

1. Jeju haenyeo, Kim Young-ae
2. You could feel my mother's sincerity and love as much as abundant ingredients cooked for the family.



The Recipe of Mung-ge-juk

✔ Ingredient

one octopus, some abalones and Obunjagi(a type of small abalone), sea urchin roe, rice. flour, sesame oil, coarse salt



✔ How to cook Jeju haenyeo's mung-ge-juk



1 Wash rice for porridge and soak it in water for about 30 minutes.



5 Stir-fry sliced abalone, Obunjagi and Geu in a frying pan heated with sesame oil slightly over high heat.



2 To remove impurities and extracts from the suckers, sprinkle enough flour on the cleaned octopus to cover all corners of the octopus and rinse thoroughly with water, rubbing as if washing the laundry.

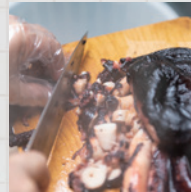

6 Take out the soft octopus that has been boiled in a pressure cooker for 30 minutes, chop it on a cutting board to make it easier to eat, and leave the boiled octopus in water.



3 Put the washed octopus in a pressure cooker, add adequate water, and add sesame (about a soju cup of oil), and simmer over strong heat for about 30 minutes.



7 The soaked rice, octopus, and the other ingredients to accompany as prepared, are all added to the boiled octopus water.



4 During the time the octopus is being boiled, cut abalone and Obunjagi diagonally to make it easier to eat. Do not throw away the savory Geu (abalone intestine), which contains the nutrients of abalone, and put it together on a cutting board for a while.



8 With the lid open, boil again for about 30 minutes, stirring occasionally to prevent the rice grains from sticking to the bottom of the pot with moderate heat control. Season to taste with salt only with coarse salt. Since each ingredient already has the salt tang of the sea, I recommend a mild taste rather than the taste of the tip of the tongue.

If it rains or the wind blows

Written by **Jwa Jung-muk**, poet & literature critic



Illustrated by **Kim Beon**

The laundry was delayed due to the strong wind and the rain signal of the weather forecast for these days, When it was time for dinner, I did the delayed laundry and hung it on the clothesline in the yard. Although the wind blew fiercely, I had to let it go, even if I could see the dust flying with the wind. The laundry piled up in one corner, socks, towels and clothes left in the washing machine were so enough that I couldn't keep them in that state. I was going to do the laundry in the washing machine first and then do the piled up laundry later. But maybe because I had old-fashioned bulgogi and soju for lunch during the day, my body became drowsy. So I came into the room to take a short nap, but evening came when I woke up.

I put the laundry back into the washing machine and waited for the laundry to be done, bothering my pets, Mongi and Byeoli, in the yard. Contrary to the news that it was getting warmer now, it seemed like winter weather was chilly as it got darker in the evening. Why the wind blows so hard in a cloudy sky. It is obvious that the puppies will bite and pull the wet laundry one by one for fun on the clothesline lowered in the wind, and if the wind dries them up even a little bit, I was going to take them into the house and dry them on the drying rack. There was so much backlog that even if I hung them on the drying rack, space would be insufficient due to a lot of laundry. Now I had no choice but to hang it on the yard clothesline until morning, whether it was raining or windy. I decided to leave small things, such as socks and towels, but I was still worried because of my puppies' behaviors with playfulness and curiosity.

Until now, the cold wind is not very different from the winter weather, but it is still spring. It is different from the winter vibes just by looking at the cloudy sky in the yard and seeing a star or the lean moon slowly walking in full moon. Although I can tell the path of the moon as a constellation, it seems that the scent of spring is mixed in the cold wind. After this scent, the tall cherry tree in the pond behind the house, and the short and fat cherry tree, would bloom like popcorn with the cherry blossoms in full bloom. In the scent of cherry blossoms, the scent of spring, which has been around for a long time, the air would be getting laden with the scent of everything around me.

The scent of spring is nostalgic sweetness. Therefore, the scent of spring spreads out even in the sky where a star glitters lonely, and even in the sky path where the moon is still incomplete, the scent of spring falls gently. Today, when the spring rain falls quietly, it is all longing and the scent of spring is filled, but why did the wind make me cry with only my heart? I have developed a strange habit for a long time and what I enjoyed is doing the laundry. Yes, that is my habit or hobby. Maybe it's boring if you tell me to do it every day, but it would have been a few times in a month. After doing the laundry, I thought the fresh scent



would be transferred to me. It seems that those laundry wobbles on the clothesline in the yard, rewarding for everything today.

"Shall we go?" "Let's have lunch together."

As in Moon Jung-hee's poem "yeah," which brings in all the energy of the universe, I say "Yeah, yeah" with "Sun and Moon/Floating Together on the Horizon/On the Ground/The Most Peaceful/Hottest Answer." Along with the wind that carries the scent of spring, a person who is more mellow than the scent of spring flies to see me in the distant countryside (meaning close to nature, not in the countryside other than in the city). Even though there is no reason to be busy, my body and mind suddenly are moving and coming to think. I have to wash my face with roughly heated water and remove the dishes piled up in the kitchen. I have to tidy up the floor and cushions, and I have to clean up the computer room roughly. Then I want to sweep the most precious yard with a broom if I have enough time. Mongi and Byuli bring all kinds of straws in the yard without missing a day. Moreover the yard is all messy because the wind is blowing today. I am about to leave the warehouse with a broom, but a familiar car has passed by in front of my house.

She is coming to me faster than the wind that contained the scent of spring. I have always told her to drive slowly, but there's no reason to blame her for coming to me anytime. She is already approaching as I open the gate and try to get to the parking lot. The scent of spring does not seem to come just by smell. Maybe the scent of spring comes with colors? The silhouette-like pink color over the head and shoulders that walks with the wind on a cloudy day is warm and fresh. So the scent of spring also comes from the most intimate and essential sense of touch. The scent of the person full of pink in his warm hands becomes the scent of spring to soothe the wait and longing.

What I always hear, or even in the morning, lunch, or evening, is "Please eat well."

A few days ago, when I ate at home, I used to want to make something with soup and eat it as if I knew I was cooking ramen and eating it roughly, but I wanted to try doenjang soup. Put some water in a pot, stir-fry anchovies and doenjang paste, pour more water, add potatoes and tofu, and boil zucchini to boil doenjang soup. When I thought about the recipe while cooking it, I first cooked zucchini in order to make the soup savory by anchovies, and to deepen the taste by adding potatoes and tofu. Food should also look good, so I wanted to cut red peppers, but as a person who can't eat anything spicy, I only put zucchini in it and boiled it.

There was a time when I ate best doenjang soup that she had made for me to have a meal with. My soup was as delicious as the soybean paste stew at that time. It's because I like Doenjang-guk so much. The Doenjang-guk a few days ago was so delicious that I thought about the process and gave it meaning. And every time I heard hello, I bragged that I had eaten two bowls of rice with Doenjang-guk for a few days. When she come home, I have been determined to make Doenjang-guk for her, but I suddenly feel intimidated in front of a genuine person who brought the scent, color and warmth of spring today.

I have always wanted to go to a local restaurant and have bulgogi, drinking soju, but I have always hesitated because I have to drink it alone. "Get us a a bottle of mild Hallasan, please!" she has just ordered. There weren't many cases where I drank a bottle of soju, but what's so nice is that when we drink a glass, she always holds a glass and toasts together with a drop of soju in her soju glass. What is more impressive is why it is so lovely to me that with her sound of 'Kyaa~' she is tasting a drop of alcohol more realistically than me drinking a whole glass of soju. Then she say "I feel the soju flavor!" Maybe she felt the taste of spring that I wanted to feel. Someone says that the most intimate thing about the senses is the taste, but we have shared all the senses today.

I do not think I want to take clean clothes in the rain, the wind, from the yard anymore. When I open the curtains and look at the yard buried in darkness and draw the tastes of the day, it feels like I'll drink all the wind. Even though the clouds in the cloudy sky are far away and you cannot see a star or the lean moon in the black sky right now, you want to draw the round face. Then, when I wake up in the morning, I might laugh by myself while watching the laundry wet with rain.



Of The Essays of Jwa Jeong-mook 「To You or Me」



Jeju Geographical Names Reading in Jeju Language

Suwolbong

Written by **Go Jae-hwan**, former emeritus professor of Jeju National University of Education



제주시 한계면 고산리 바당굿딘 수월
봉이랜(앤) 혼 노픈 동산이 잇수다. ‘녹고무루’랜
(앤) 불르는 그 수월봉엔 이제부떠 350년 전, 이 무
슬에 살던 수월이랜(앤) 혼는 누이영(광) 녹고랜(앤)
혼는 남동싱의 이와기라(가) 전 혼(여) 읍네다.

일찍이 아바질 여이언 가난 혼 살림이주만 노몰 뉘서
그네 행복하게 살던 오누이신디 뜬금엇이 일이 생겼
수다. 어느 해 봄, 노모라(가) 몸썰 빙에 걸려
그네 자리에 눕게 뉘엇인디, 날이 가다지 점점 빙
세라(가) 위독 혼(여) 갓수다. 옛인 살림에도 이약
저약, 종텐 혼 약은 다 써뵈주만서도 아무 소괄 보지 못
혼(여)그네 오누인 매날 부둥켜안양 울기만 혼(여)
수다.

어느 날, 혼 스님이 지나다그네 이덜 오누이라(가) 울고
잇인 걸 보안 그 77닥을 물엇수다. 스연을 들은 스님은
오누일 가읍(엿)게 예겨그네 백 가지 약출 알려주멍 그
약출 문딱 혼디 모뉘그네 딸여 먹으민 어머니 빙이
낫일 거랜(앤) 알려줘근 떠뉘수다. 그날부뉘 수월광
녹곤 이산 저산 땡기멍 약출 캐기 시작 혼(여)고, 무춤
아은아읍 가지 약출 캣수다. 혼주만 안타깝게도 단 혼가지
약초만은 좇질 못 혼(여)인디, 그 약초 일름은 ‘오갈피’
인디, 스님의 말에 뜨르민 노픈 바위나 산비클 77튼 디
잇넨 혼(여)수다.

약출 좇앙 해매멍 무슬 앞 바당굿 가프른
영장(벌뵈) 읍을 지나단 무춤내 영장 중간쑤에
스님이 알려준 ‘오갈피’라(가) 부터 잇는 걸 좇아
내게 뉘엇수다. 이걸 본 순간 오누인 주저홀 어간도
엇이 동산 우터레 올랐수다. 약출 캐기 읍은 영
장을 누르(려)가사 혼(여)고, 수월인 녹고의 혼착
손을 심어그네 혼 발자국쑤 누르(려)가기 시작 혼(여)
수다.

다앵이 약출 캐어그네 지뵈 뉘음으로 녹고신디 좇일 때,
수월인 너미 흥분하고 심들엇던 터라 정신을 일러불고
말앗수다. 녹고도 약출 받는 순간 지뵈에 제완 심엇던
수월이 손을 오뵈 놓쳐불엇수다. 수월인 여지엇이 그
힘 혼 영장 알더레 혼장엇이 둥굴어근 털어젼수다. 녹
고는 순간 가슴이 무너져그네 울부짖단 정신을 일러수다.
얼매 후 정신을 추린 녹고는 이녁이 손을 놓쳐 누일
죽게 혼(여)덴 주책감광 슬픔에 영장 중간을 떠나지
못 혼 채로 쑤엇이 울기만 혼다그네 누이 주짖더레 갓수다.

이때 녹고라(가) 흘리던 눈물은 아직도 바위트망을 거
쳐그네 쑤엇이 ‘녹고물’이랜(앤) 혼 일름의 산물로 솟아
올람(얇)수다. 아득 혼 뒷날, 무슬이선 이 동산을 ‘녹고무
루’, ‘녹고물오름’, 포시 누이의 일름을 따그네 ‘수월봉’
이랜(앤) 불림(얇)수다.

Standard Language
Interpretation

There is a high hill called Suwolbong on the beach in Gosan-ri, Hankyung-myeon, Jeju-si. From now on, the story of Suwol, a sister who lived in the village 350 years ago, and Nokgo, a younger brother, has been told there, also called Nokgoru.

They were brothers and sisters who lost their father and lived happily with their elderly mother. But all of a sudden, my old mother became seriously ill and lay down. Their mother became increasingly ill day by day. They used all the medicine that was good for their mother, but it didn't work, so they hugged and cried every day.

One day, a monk who was passing by saw the brother and sister crying and asked why. He felt sorry for the brother and sister and taught them a hundred herbs, telling them that his mother would be healed if they were collected and fed together. Suwol and Nokgo started digging for herbs in discrete low mountains, and they finally dug up ninety-nine herbs. Unfortunately, however, they couldn't find the last herb, which is called 'Ogalpi,' according to the monk, it is located on high rocks or mountain slopes.

While searching for herbs, the brother and sister were passing by a steep cliff in front of the village, and finally found the "Ogalpi" that the monk told them about halfway through the

cliff. They climbed up the hill without hesitation. To dig for herbs, Suwol and Nokgo had to go down the cliff, and Suwol took one hand of Nokgo and began to go down one step at a time.

Fortunately, Suwol dug up the herbs and happily delivered them to Nokgo, and she was so excited and tired that she lost her mind. Nokgo was distracted by the joy of receiving herbs, so he missed Suwol's hand. She rolled down the steep cliff without a doubt. As soon as his heart melted, he cried and lost his mind. Later, Nok-go, who came to his senses, cried endlessly on the spot with guilt and sadness that he himself let go of her hand and made her die. And then he went to her side.

At this time, the tears of Nokgo are still rising endlessly from the cracks of the rocks into a spring named "Nogomul". In the distant future, the village calls this garden 'Nokgoru', 'Nokgomulorum', or 'Suwolbong', which is derived from his sister's name. 212

Illustrated by Lee Areum





Beyond Jeju agriculture,
take a big step to lead the Jeju industry

「Jeju Agricultural and Rural Community 6th Industry Support Center」

Written by Editorial Staff /

Photo in courtesy of Jeju Agricultural and Rural Community 6th Industry Support Center

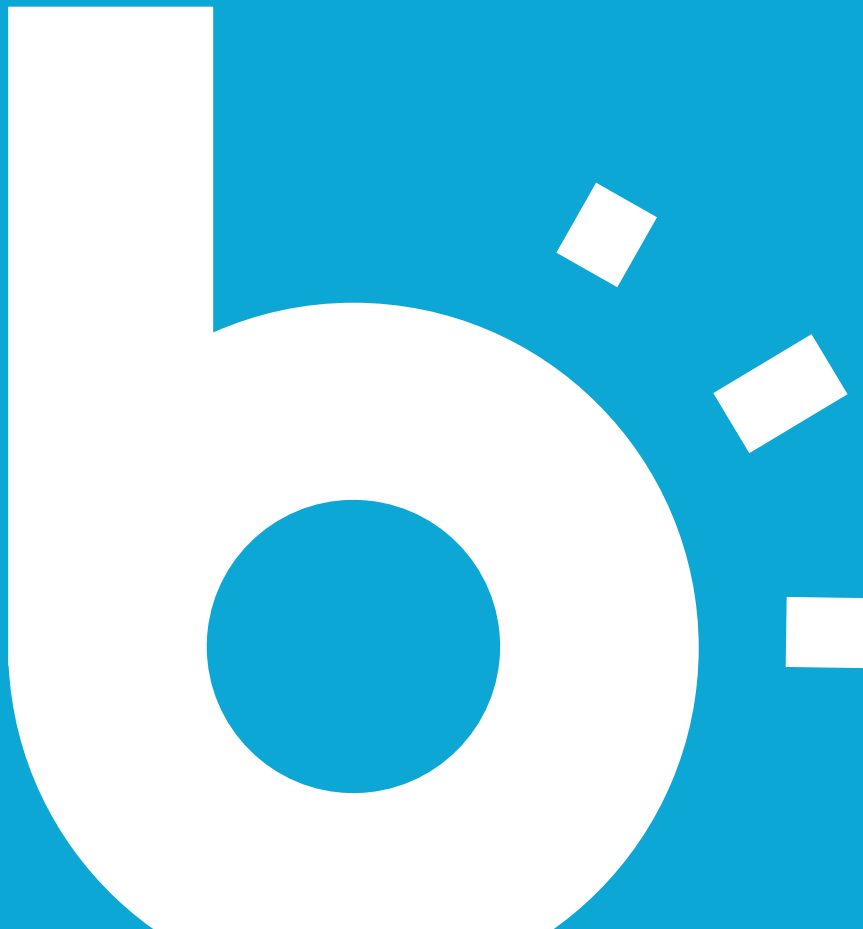

You often hear the word "future food". It means "Something that will feed the parties involved in connection with each industry in the future." . After COVID-19, it became a word that should be considered with more interest. As unexpected changes have occurred not only in everyday life but also in society and industry as a whole, businesses that have focused on future food are required to change their direction according to the trend of change. This is because it is necessary to change the target to business items suitable for the so-called "post corona era" or "with corona era," and modify the business method and direction in an appropriate manner.

Finding new "food for the future" that meets the changed environment and prospects for the future may determine the success or failure of the future for several years or even decades. This is a time when choice and concentration are more important than ever.

According to the demands of the times, Jeju Island is establishing and implementing various policies to promote leading projects. A representative example is the "Jeju-style New Deal Policy". In addition, the "Jeju-type 6th industry" was selected as a key growth engine for the "future Jeju agriculture". Through these, we are taking a big step to grow not only Jeju agriculture in the future, but also the basis of Jeju industry in general.

Let's meet Soon-Hwa Ahn, head of the Jeju Agricultural and Rural Community 6th Industry Support Center, and hear about the current status and prospects of Jeju's 6th industry, and a sketch for the future Jeju industry.



The core of the 6th industry is to expand the products produced in the primary and secondary industries into high value-added service industries such as experience and tourism. © Morning Smile Co., Ltd.

First of all, please explain what is the 6th industry.

The 6th industry refers to an industry in which all well-known primary, secondary, and tertiary industries are fused and combined.

For an easier example, in Jeju Island, tangerines are representative agricultural products. This kind of citrus cultivation is the primary industry. Citrus can be supplied fresh to consumers, but it can

also be made of citrus jam, juice, and citrus syrup, and this manufacturing and processing process is the secondary industry. Products produced in this way are not just supplied to consumers through the distribution network, but also to experience, tourism, and services such as citrus picking experience or making citrus syrup. The type of industry in which these primary, secondary, and tertiary industries are all joined together is called the sixth industry.



On-site support at the third flea market held by the Jeju 6th Industry Association. Various support projects are underway to promote products and increase sales of Jeju 6th industry certified businesses.

Although citrus is an example, I wonder if Jeju's infrastructure is suitable for the sixth industry and how competitive it is compared to other cities and provinces.

Jeju is the best place for the sixth industry. Tourism, which accounts for more than 70% of Jeju's industry, is the best infrastructure for Jeju's sixth industry. Jeju's sixth industry has optimal conditions, including clean image, three-time UNESCO natural sciences, Jeju Stone Wall, Jeju haenyeo, and Chilmeori Danggut, a folk culture.

It was a big drop last year due to COVID-19. However, more than 10 million tourists are still visiting Jeju Island annually, and it is attracting attention as almost the only vacation spot to fly to these days when it is difficult to travel abroad.

Among the 6th industries, the 1st and 2nd industries do not differ significantly by region. Rather, it can be considered that Jeju Island, where manufacturing facilities are relatively scarce, is poor. It is the tertiary industry such as tourism, experience, and service that can overcome these limitations.

What are the 6th industry support and development measures currently in place at the center?

The business operated by the 6th Industrial Support Center is divided into three main areas.

The most representative support project is the "6th Industrial Business Certification System". When a business operator or a business entity promoting the 6th industry requests business certification to the 6th industry support center, it is not simply reviewing the documents to determine whether it is certified, but also consulting on documents or items that are difficult to prepare or implement by the business operator. It is to support business certification under optimal conditions.

The fact that the business is certified by the state and province can be seen as a product competitiveness.

Products and services that have been certified through rigorous standards and screening serve as an opportunity



for customers to narrow their options as "trustworthy products and services".

Currently, there are 115 6th industry certified companies on Jeju Island, and they are expected to gradually expand.

Next is on-site coaching.

In addition to the certification projects mentioned earlier, consulting and field coaching are conducted in almost all areas required by 6th industry operators (product development, corporate operation, promotion and marketing, process management, manufacturing facility renovation, experience program development, etc.). There is no fixed field of application, but when the operator requests support, it becomes a field of support.

Currently, 105 coaching professional members are registered, and if there are no suitable members among them, coaching will be conducted in conjunction with other cities and provinces to reduce the professional members.

Third support, antenna shop operation. It is literally a place to collect information.

It is a kind of test space for promoting and selling 6th industry certified products by installing in places where consumers are frequent, and to grasp consumer tendencies and reactions and reflect them in product planning and production.

Antenna shops operated by Jeju 6th Industrial Support Center are three E-Mart stores in the province, Mok-dong and Yongsan E-Mart stores in Seoul, and Seongsanpo stores in Jeju.

Is there any particular memorable case of the 6th industry support project?

It's not a specific case, but the certification renewal rate is relatively higher than in other regions. Although Jeju failed to achieve the top spot in the nation's 11 support centers, it ranked fourth in the country with an 87 percent renewal rate. The re-certification process, which takes place every three years, is not only easy in preparing documents or procedures, but I think the high renewal rate proves that the sixth industry certification is effective and influential in the business.

And the operators' satisfaction with the certification mark is quite high. Both operators and customers are satisfied with the fact that the certification mark guarantees the quality of the product.

All industries are having a hard time with Corona 19. Each industry is trying to find a way to overcome it, what is being sought in the 6th industry?

The number of tourists, which was more than 15.28 million in 2019, has decreased significantly to two-thirds, barely exceeding 10.23 million last year. Therefore, it is true that sales of 6th industrial products have decreased significantly. This is because it has been relatively dependent on offline sales networks to promote and sell.

In order to actively respond to changing consumer tendencies and environments in the future, we are promoting the development of distribution platforms for Jeju agricultural products and Jeju 6th industries by establishing an online sales network based on smartphones.

First of all, by providing a variety of information to consumers online through the establishment of various DBs, the seller also eliminates sales commissions and minimizes logistics costs through an independent integrated distribution network, rather than through existing Internet shopping malls, so that customers can achieve high quality at a more reasonable price. It is to build a system that allows you to easily purchase certified products. As a result, we plan to run not only B2C (sellers and individual consumers) of online sales, but also B2B (sellers and companies) or B2G (sellers and government) businesses that provide information to vendors who want to wholesale and retail.

The 1st 6th Industry Jeju International Expo Purchase Consultation Meeting in 2019





1. Various products displayed in the 6th Industry Support Center
2. The first 6th Industrial Expo held in 2019
3. The Startup School Tour to Advanced Areas in Jeju in 2020
4. Capacity-building Education through non-face-to-face online
5. The Jeju Food Fair in 2019

In 2021, the Jeju Provincial Government has expressed its will and plans to develop the 6th industry as a key growth engine for Jeju agriculture. For that reason, there will be many follow-up measures. What do you think is the most important and urgent for fostering the 6th industry?

The most important thing is to build an integrated platform to vitalize the Jeju 6th industry. In addition to the distribution platform mentioned earlier, we need a hub center that covers everything, including facilities for product development and testing, packaging support, prototype manufacturing, promotion and sales and distribution network operation, tourism and experience program development and information sharing.

So far, the sixth industry has talked about convergence between industries, but has expanded mainly to manufacturers with manufacturing facilities. However, essentially expanding the sixth industry and for a high value-added industry, we need channels for each level of industry to be joined and interacted with each other industries.

It's not a matter of time for farmers who are busy farming, but if they are interested in farming, it's a different problem if they have a facility to make and test the products they want. In most cases, they want to try various attempts to create added value, but they cannot even challenge themselves because they do not have adequate facilities or information.

There is a need for a place where processing facilities for prototype production, design centers and facilities for packaging, on- and off-line systems for distribution, and consulting that can be expanded to experience and tourism products are provided. In my own way, such a place is called an integrated platform. It is urgent to build an integrated platform.

What are some of the directions for the Jeju-type 6th industry?

I think that the most Jeju-like is the best competitiveness. It is necessary to develop products that make the most of the best brand value of 'Jeju'. In that sense, Jeju's identity is somewhat lacking in Jeju's 6th industrial products.

To overcome that, the identity developed by our center is Farming +

Jeju.

Farming, meaning a combination of agriculture and Jeju, is a slogan and brand that also means a clean product cultivated and cultivated by Jeju. Currently, the sixth industry certification mark is written on the sixth industry product, so the customer recognizes the quality and value of the product. If the image of Jeju is added to it, the effect will be much greater. Jeju's sixth industry can grow only when it expands its image as "Jeju" is clean and "Farming Plus Jeju" is the best clean product.

Lastly, as the 6th head of the Industrial Support Center, please send a message to the residents and readers.

What I want to ask for is interest. Although it is true that the 6th industry is still in its infancy and lacks proper results, I think this is not just a matter of performance and performance. We are looking for food and ways to live, so we need everyone's attention and understanding.

If you see a product with the 6th industry certification mark, please look at it with a good eye. If you buy it, it will be an opportunity for Jeju's agriculture to grow and Jeju's industry to grow. Jeju's sixth industry is an industry with enough growth potential and capacity. Jeju's "future food" is located in clean Jeju's healthy agricultural products and natural environment. I look forward to cultivating Jeju Island with the best quality products and services that people all over the world admire. 🌱



In 2020, the 6th Industrial Jeju International Expo, which had been scheduled to be held due to COVID-19, took place through non-face-to-face online.

Jeju, a leading electric vehicle city that practices Jeju's clarity

Written by Editorial Staff /
Photo in courtesy of Jeju Special
Self-Governing Province



Which region has the highest percentage of eco-friendly electric vehicle registration in Korea? Most would have expected, Jeju has an unrivaled dominance in electric vehicles compared to the total number of car registrations. (From 394,649 registered vehicles in the province, there are 21,285 electric vehicles, 5.39% / as of the end of December 2020). This is just the rate of registration. Compared to Seoul and Gyeonggi Province, which have overwhelming population density and number of vehicles, Seoul has the largest number of electric vehicles with 23,393 units, while Jeju ranks second with 21,285 units, ahead of 20,477 units in Gyeonggi Province. This is the true image of Jeju, a leading city for electric vehicles.

Starting with the designation of a leading city for electric vehicles in 2011, Jeju prepared a basic plan for a model city for electric vehicles as a key project for its 'CFI JEJU by 2030' plan in 2012 and has been supplying

electric vehicles to the private sector for the first time in Korea since 2013. The goal is to fundamentally block greenhouse gases and pollutants caused by cars by replacing most of the vehicles in the province (75% target as of 2030) with electric vehicles. In addition, it is planning to respond 100% of electric vehicle charging power and electricity demand in the province with wind power, solar energy, and other renewable energy.

Increasing the penetration rate of electric vehicles may not only be an issue of environmentally friendly policies, but also a matter of securing Jeju's future. Protecting the natural environment, Jeju's only resource, and increasing the brand value of clean image Jeju is preparing for the future for Jeju and its residents to live in. Attention and cooperation from all provincial residents are needed.

Let's look into the future of clean Jeju through various support policies and projects related to electric vehicle supply projects to practice Jeju's clarity.



Project to supply electric vehicles in Jeju Island in 2021

Since Jeju Island started its first private electric vehicle supply business in 2013, it has steadily expanded the number of electric vehicles through continuous business. However, the number of new electric vehicle registrations has declined over the past three years. The reason for the decline is that subsidies for the supply of electric vehicles continue to decline.

Electric vehicles are difficult to purchase without government or local government support because the factory price of electric vehicles is up to two times higher and at least 1.5 times higher than that of general internal combustion engine vehicles.

The scale of subsidies in Jeju Island has been gradually decreasing since 2018, and has been reduced every year from 18 million won to 14 million won (2019) and 13.2 million won (2020), combined with the government and government expenses. The amount of subsidies this year has dropped to 12.5 million won. The reason why subsidies continue to decline is that due to limited government subsidies, the size of government subsidies allocated to Jeju so far is relatively decreasing as local governments revitalize electric vehicle supply projects. In addition, it is also because the budget for electric vehicle distribution to the private sector was reduced to prepare a budget related to Corona 19.

Although the electric vehicle supply project is not meeting the expected target due to budget problems, efforts to expand the supply of electric vehicles for the future of the “Clean Jeju” are continuing this year in 2021.

This is an overview of the electric vehicle distribution business in 2021.

Subsidies for electric vehicle supply projects are basically promoted through public offerings with a limited time limit and scope. If you are planning to purchase an electric car, it is good to know the contents of the competition in advance.



Go to Notice of
Electric Vehicle
Supply Business

 **Application period** : 2021. 2. 17. ~ 2021. 12. 31.

※ Until budget or quantity is exhausted

 **Application place** : Electric vehicle sales and sales outlets in the province (42)

※ However, except for electric vehicle manufacturers and importers who do not have electric vehicle sales and sales outlets in the province.

 **Number of supplies** : Within the range of 4,246 electric vehicles (Car 2,046, Truck 2,200)

※ The number of supplies may vary depending on the supply conditions and budget increase.

 **Supply vehicle type** : Supply vehicle type: 67 types of electric vehicles (54 types for use, 13 types for cargo)

※ Vehicles selected for future electric vehicle subsidies will be included in the subsidy list without any change notice.

Selection Criteria and Application Procedure : Order of application for purchase

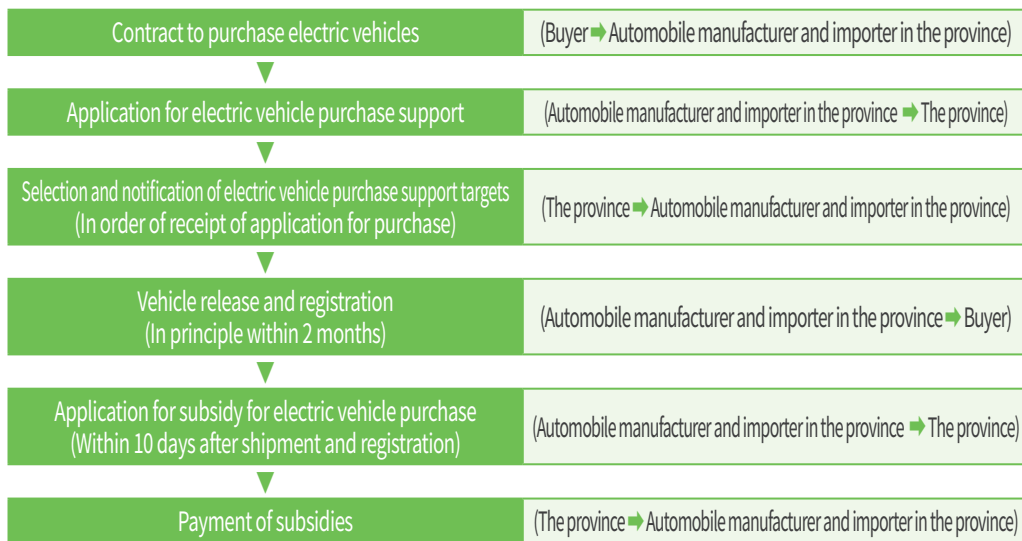

Qualification of application : Jeju residents (individual and individual business operators, corporations, corporations, etc. in the province)

- ※ Individual and private business operators reside for at least three months before the date of application, and enterprises and corporations are established for at least three months before the date of application;
- Jeju residents aged 18 years or older (minimum age for qualification for driver's license test) who have addresses in the province
- Overseas nationals and domestic permanent residents (F-5 visas) residing in the province and international school workers in Jeju English Education City (E-7 visas)

Criteria for supply : 1 individual/individual business operator (same vehicle type), 1 company/corporation (within 50 passenger units, 1 cargo)

- ※ If a company or corporation applies for purchase support for a large amount of electric vehicles, a business plan may be requested, and subsidies may not be provided depending on the business content and supply status.

Subsidy support

Sortation	Passenger		Cargo			
	General	Microminiature	Small	Small Special (Freezer Truck)	Light	Microminiature
Total	1,250	800	2,200	2,700	1,600	1,000
National expenditure	800	400	1,600	2,100	1,100	600
Cost in province	450	400	600	600	500	400

(Unit:10,000 won)

- Electric vehicle standard : 12.5 million won
- In the case of general government-funded support for passengers, 10% additional support (8.8 million won) when the second-tier ranks purchase, 2 million won additional support for electric taxi purchases (10 million won) Based on electric car: 12.5 million won
- Since support may be limited for electric passenger cars and trucks and some imported cars, refer to “2021 Private Electric Vehicle Supply Project Competition” for details.



Advanced Charging Infrastructure Demonstration Project

Jeju Island has advanced its charging infrastructure for electric vehicles in the "Jeju Electric Vehicle Charging Service Special Zone" and prepared for electric vehicle performance and condition diagnostic services in advance. Therefore, the demonstration began on January 21, 2021.

This demonstration showed a high rate of penetration of electric vehicles. In addition, Jeju, which is leading the electric vehicle market, was implemented to resolve inconveniences caused by charging electric vehicles through the Special Regulatory Free Zone and preemptively respond to the revitalization of used electric vehicle transactions.

First of all, the demonstration project of upgrading the charging infrastructure is a project that enables rapid charging of 100 kw through the existing 50 kw rapid charger by adding an energy storage system (ESS) with a capacity of 50 kw to the 50 kw rapid charger already in operation.

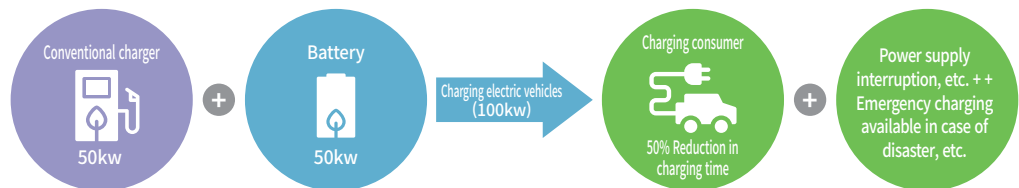

Reducing the costs of a installation by utilizing the existing installed charger

When using the existing 50kw fast charger, it took about 40 minutes to charge the electric vehicle to the 80% level. However, in the case of 100kw combined with ESS, the charging time is reduced by about half to 20 minutes, and emergency chargers can be used even in the event of a disaster such as an interruption in electricity supply. Above all, it is very effective in cost reduction as it can achieve advanced performance without replacing the existing quick charger.

Until now, there was a difficulty in commercialization because there were no certification standards for chargers incorporating ESS, but a special case was granted to establish certification standards through special regulatory free zones.

Mobile battery diagnosis service demonstration business

By operating a mobile performance inspection vehicle related to electric vehicle (battery) performance and condition diagnostic service, it is easier to identify abnormalities in vehicles and residual value of used vehicles.

Under the "Automotive Management Act," the inspection of automobiles is allowed only in specific locations reported to local governments, but through this demonstration, it is possible to inspect the vehicle by moving a performance inspection vehicle equipped with special equipment to a location desired by the customer. Through vehicle inspection, it is possible to diagnose the number of times or performance of the used electric vehicle's battery charge/discharge, calculate the current value of the vehicle, and provide information for reference when trading a used car. This information is expected to enable active used electric vehicle transactions and further increase the level of trust and satisfaction among users.

The performance and condition inspection process is as follows: ① Customers apply for performance and condition inspection of used electric vehicles ② Move mobile performance inspection vehicles to designated locations ④ Check battery charging efficiency and condition ⑤ Check internal combustion engines for simplified diagnosis. The inspection takes about 30 minutes, and you can get the results right after the inspection.

We hope that the full-scale commercialization of various businesses, such as the advancement of charging infrastructure and battery inspection services through ESS, will increase the purchasing power of electric vehicles and become a good signal for the expansion of electric vehicle distribution.



2021 more information, more benefits

Arranged by Editorial Staff / Data in courtesy of Jeju Province

Here are useful tips that benefit you if you know of the new or different provincial government policies for Jeju residents in 2021.

The so-called wise secret of living in Jeju is soon revealed.

Residential Transportation Sector

01

Save Transportation Fare Card Mileage Support Project

To encourage public transportation, a budget transportation card support project will be implemented to save up to 30 percent of public transportation costs, up to 11,000 won a month by accumulating mileage as far as walking or cycling.

Business outline

- ◆ **Target for support** : Jeju residents over the age of 19 (users of alcard)
- ◆ **Support contents** : When using a bus at least 15 times a month, mileage support is provided in proportion to the distance traveled by pedestrian or bicycle

One-time transportation fee	Less than 2,000 won	2,000 won to 3,000 won	3,000 won or more	Note
One-time mileage payment (Up to 44 times per month)	250 won (11,000 won)	350 won (15,400 won)	450 won (19,800 won)	Payable when moving 800m (If it is less than 800m, the distance is proportional)

* Additional support of 100 to 200 won for the low-income class (secondary class, basic living recipients)

◆ Support method

- 1) Card application and issuance - On the alcard website (<https://www.alcard.kr>)
- 2) After receiving the card, install the 'alcard' app on the mobile phone and sign up for membership (card registration)
- 3) When using public transportation, use the app and pay with a alcard (including boarding and dropping tags)

On departure	When boarding public transportation	When getting off public transportation	Upon arrival at destination
Click [Departure] in the app	AlCard with Ride Tag	Get off tag with a AlCard	In the app Click [Arrival]

- 4) Accumulate mileage by measuring the walking distance in the app before and after getting on and off
- 5) If accumulated more than 15 times a month, mileage is paid for the following month (card discount or charge)

Effective date February 1, 2021



Changes in 2021

- ◆ When using public transportation more than 15 times a month, mileage is paid in proportion to the distance traveled.
 - Maximum mileage up to 11,000 won per month based on bus fare of 1,200 won
- ◆ Up to 30% reduction in transportation costs (approximately 20% mileage, 10% discount from credit card companies)

Department of Public Transport. (710-4331)

02

Ten million won+ Happy I Policy implementation

In order to alleviate the economic burden of childbirth and child-rearing for multi-child families, we provide housing rental expenses (14 million won) or child-raising support (total of 10 million won) from the second child.

Business outline

- ◆ **Target for support** : As the father or mother of a second child born or adopted on or after January 1, 2021.
 - A father or mother who has been living with a child born (adopted) with an address on resident registration in Jeju Special Self-Governing Province from 12 months before the date of birth (adoption) of their child .

- * If the period of residence of the father or mother is less than 12 months, it is possible to apply from the day after 12 months have passed.
- * Birth (adopted) children must be reported as birth (adopted) in Jeju Island, and must be registered on their father's or mother's resident registration card.
- * Adoption is limited to adopting a child 48 months or less from the date of birth.

- ◆ **Support contents** : Choose one of housing rent (limited to homeless households) or child-raising support

Section	Housing rent	Child-raising support
Support amount	14 million won over 5 years (2.8 million won/year)	10 million won for 5 years (2 million won/year)

※ Home-owned households: Households that do not own a home (acquisition of inheritance) on a national standard, including housing and distribution rights (portion in co-ownership), based on the applicant and spouse

- ◆ **Support method** : Cash payment (transfer account) /
Equal installment for five years (paid once a year)

Effective date February 1, 2021



Changes in 2021

- ◆ **At the time of childbirth (adoption) from the second child.**
 - Support in installments for five years by selecting one of the housing rental expenses (14 million won)

03

The Youth (Job) Toring Support Project

The Youth (Job) Toring* project is to strengthen the foundation for youth's independence by actively responding to environmental changes caused by the prolonged Covid-19 and providing them with opportunities to seek a new career path through mentoring. *(job)Toring: Start-up+Mentoring

Business outline

- ◆ **Business period** : April to December 2021
- ◆ **Target for support** : Youth between 19 and 39 years old living in the province
- ◆ **Support contents** : Operation of programs to support young people's employment and start-ups
 - Online and offline career exploration mentoring to support young people's employment and start-ups.
 - Produce profiles for job search and job understanding
 - Online publication and sharing of ment
- ◆ **Support procedure** * The application procedure is adjusted in accordance with the consultation with the performing institution.

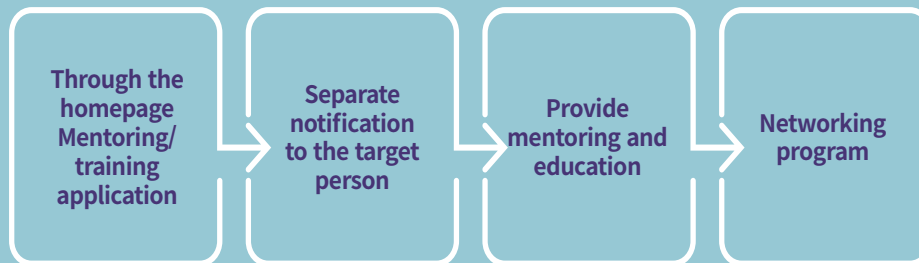

Effective date April 2021

Changes in 2021

- ◆ Mentoring and networking support for young people in the province to explore their lives and work and explore new careers.
- ◆ Support for job search and reinforcement of the foundation for independence through the use of online platforms in response to the new normal era



Recyclables collection integrated compensation system event

Regardless of the type of waste batteries, paper packs, cans, and transparent plastic bottles, the weight is integrated at the recycling center in the province. We exchange compensation for 10 sheets per 1 kg on Recycling Day.

Business outline

- ◆ **Operating Time** : From April 2021 to~
- ◆ **Place of operation** : Recycling Help Center in the Province
- ◆ **Operating hours** : Operating hours for each recycling help center
- ◆ **Target Item** : ① Waste battery ② Paper Pack ③ Canned goods ④ Transparent PET Bottle
- ◆ **Compensation criteria** :
 - Measures the integrated weight of the above target item, not the individual weight
 - Daily life: Measuring bag per kg (10ℓ=240 won) 1 sheet (maximum of 5 kg (5 pieces))
 - Recycling Day: 10 bags per 1kg (10ℓ=240 won)
 - 4th Sunday of every month or environmental anniversary*
 - *Environmental anniversaries: Earth Day (4/22), Biodiversity Day (5/22), Environment Day (6/5), Ozone Layer Conservation Day (9/16), Blue Sky Day (9/22)

Section	Compensation standard (10ℓ of pay-per-use bag)				
	1 kg or more Less than 2 kg	2 kg or more Less than 3 kg	3 kg or more Less than 4 kg	4 kg or more Less than 5 kg	5 kg or more
Usual	1sheet	2sheet	3sheet	4sheet	5sheet
Recycling Day	10sheet	11sheet	12sheet	13sheet	15sheet

Effective date April 2021 to~

Changes in 2021

- ◆ Reward exchange of 10 sheets of waste batteries, paper packs, cans and transparent plastic bottles per 1 kg of waste batteries at the Recycling Help Center on the fourth Sunday of every month



READERS' FORUM

The postcards from readers



I especially liked the photosketch pictures in the '2020 winter magazine'. "Camellia colony, snow-covered Jeju horse grazing land, paradise of migratory birds, and the sunrise of Seongsan Mountain at the end of the year." It is also good to see and see the scenery of Jeju Island. And it was even more fun because poet Kim Se-hong I know was introduced. I am very interested in Jeju mythology, and 'The Story of the Party and God' was very informative.

Sa Yoonsoo Haedong-ro, Dong-gu, Daegu



I also read the conversation on page 19 of <Jeju> with great empathy as I want to obtain a certificate as a tourist interpreter and develop practical skills in related fields. Also, I hope there will be more events such as overcoming corona messages. Among them, the phrase 'Spread LOVE, Not COVID-19' was touching and good.

Yu Chaeun Andeokbeol-ro, Cheongwon-gu, Cheongju-si, Chungcheongbuk-do



"Jeju-style New Deal leading the era"

By effectively responding to the three areas of the New Deal (Green, Digital, and Safety Net Enhancement), this article demonstrated Jeju Island's task of integrating two propositions, "Environment" and "Development," by striving for cleanliness, smart, safety and cohabitation. At the same time, I think it was a well-revealed article of the necessary solution.

P.S: In the digital age of magazines turning into webzines, this valuable magazine, <Jeju>, published in paper... Please maintain it continuously.

Kang Yeongsuk Gilju-ro, Bupyeong-gu, Incheon



When I was a kid, I used to hear the words "black calves at the same price." But, I haven't heard the answer to whether black cows are better in quality. It was useful to know the answer after reading <Jeju>. Nowadays, imported beef is said to be Korean beef if it is raised in Korea for only three months, but I think the mixed-grown cow is the right name. I think Jeju black beef is the best. I love Jeju.

Choe Haejeong Geumseong-ro, Gyeongju-si, Gyeongsangbuk-do



"Jeju's winter story where both birds and people fly"

It is as interesting as it makes us know the ecology of birds in the natural landscape. I was curious about the bird I found in Sanjicheon, Jeju, so I asked the person who posted a picture of the ecological bird on SNS, and it was "heron."^A^

- skip. - "When a heron flies, it flies along with a spoonbird." - skip. It's really fascinating to feel like I'm out of the layperson. It feels like being invited to their world.

Gang Yeonok Seogwang-ro, Jeju-si, Jeju-do



Reading "'Green New Deal Frontier, Jeju'" and related to the Korean version of Green New Deal, Jeju-type Green New Deal is expected to liberalize power transactions, transform smart green mobility, foster 100,000 future innovative talents, and hold a general meeting of the Climate Change Convention in 2023.

Hong Jaegyong Hwamyongsindosi-ro, Buk-gu, Busan



"Jeju Doggegi (pig) of Geumak to bring wealth"

I knew that pork in Jeju Island is famous. After reading the story of Isidol Ranch created by the priest, I realized that there was a history like this.

I enjoyed reading Jeju's unique story and up to the 3rd leader of Dotgewegi.

Cha Sujeong Imbangul-daero, Gwangsan-gu, Gwangju



All the articles in this magazine were good, but the article in "The bungeoppang poet who bakes love" was especially impressive. Poet Kim Se-hong's love for the world was contained in the fish-shaped bun, so I looked more closely. As a bungeoppang poet who continues to bake love, I look forward to your active poetry activities.

Bae Myeonghui Namdong-daero, Namdong-gu, Incheon



I was pleased to know everything about the Jeju black cow (history, excellence, current appearance, etc.), which is called Jeju's black treasure.

Cho Hanseok Namdong-daero, Namdong-gu, Incheon



I was pleased to know everything about the Jeju black cow (history, excellence, current appearance, etc.), which is called Jeju's black treasure.

Cho Hanseok Omok-ro, Uijeongbu-si, Gyeonggi-do

Jeju filled with my own color

The landscape of Jeju winter

 syj080130(Seong Yeonjun)



Hello, I'm a student who will be in the first grade of middle school. I had a lot of time at home because of Corona 19 and vacation, but I was able to relieve my boredom by coloring and recall the memories of going to Jeju Island before Corona 19. I hope Covid-19 ends soon so that I can travel to Jeju Island freely again.

 goodever4u(Lee Seonghun)



Coloring this painting, Jeju's beautiful sea, bright sky, friendly oreum, camellia with deep vitality, and citrus that seems to be still fresh in my mouth, and Jeju, which I have visited once or twice a year..Thank you for feeling Jeju itself for a moment. ~I look forward to the day when I can go to Jeju without worrying about Corona.~~

 helen0825(Yun Jayeong)



After returning from kindergarten, my son Hoyeon brought the newsletter in the mailbox. He began to paint pleasantly, and he drew that the plane was missing in the empty sky, and completed the seagull in detail. The sea was painted the same as the sunset and the fish was drawn on the sea. He marks his hat and mask like a kindergarten student.^^

 goldkyong(Kang Eungyeong)



코로나19로 인해 집콕하는 아이들과 함께 이색 이벤트 컬러링 제주 함께 식탁에 모여 색칠하다 보니 아이들도 재미있어하고 저 역시도 흥미로웠습니다. 앞으로도 다양한 이벤트 많이 해주세요.

We look forward to your participation.



Thank you for your interest in and support for Jeju provincial newsletter JEJU. Please feel free to send us your candid review on the postcard during or after reading the newsletter. We welcome anything from comments about articles or segments, to suggestions for improvement and to article proposals or reports. We will select comments, suggestions or ideas worth sharing and publish them in our next issue and send those selected a gift as a token of appreciation.

Open to All readers of JEJU
Until May 2021
How to participate Please write your comments, name, and contact information on your post card
Announcement to be announced in the Summer issue of JEJU, 2021

한저읍서예



World Natural Heritage, Jeju

The mountain and the sea recognized by not just Korea and the whole world.
From the lush forest to a handful of soil and to wildflowers,
Everything in Jeju is the greatest gift that nature has ever given to mankind.
While walking on trails, climbing mountains and volcanic cones, and visiting islets around Jeju,
The weight of daily lives is lightened and a little smile is brought to your face.
It is what Jeju is all about, an island of healing.

